

OWNER'S MANUAL

5650

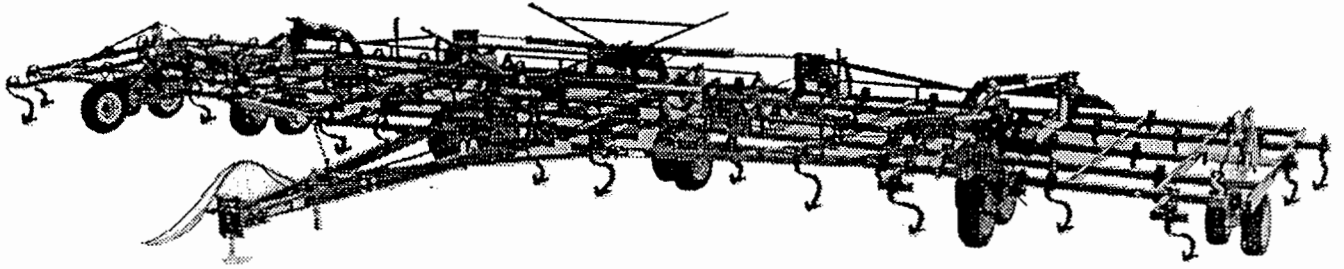

FIELD CULTIVATOR

MODELS

5648, 5654, 5660

Serial No.

1137

REVISED

JAN 1998

KRAUSE

P.O. BOX 2707, 305 SOUTH MONROE STREET HUTCHINSON, KANSAS 67504-2707

Congratulations

You have just purchased a quality designed and manufactured Krause tillage tool. Advanced features have been designed into the implement for modern farming operations. As with any investment, a return is expected, and the return received from this investment will be in the form of maximum tillage performance during many years of dependable service.

In order to maintain quality performance of the new Krause implement, it is important that all of the information in the manual be reviewed and studied carefully before operation. The contents provide operating instructions, maintenance instructions, and information on how to make adjustments.

SAFETY ALERT SYMBOL



**BE ALERT TO THE POSSIBILITY OF
PERSONAL INJURY. THIS SYMBOL
IDENTIFIES IMPORTANT SAFETY
MESSAGES. CAREFULLY READ THE
MESSAGE THAT FOLLOWS.**

MODEL NUMBER _____ SERIAL NUMBER _____

PURCHASE RECORD -- DATE _____

Warranty

KRAUSE PLOW CORPORATION Hutchinson, Kansas

The Krause Plow Corporation, Hutchinson, Kansas, expressly warrants each new product manufactured by it to be free from defects in material and workmanship under normal use and service for a period of one year after delivery to the original retail purchaser or first user of the product.

Krause's obligation under this warranty is limited to repairing and/or replacing, at its option, any part or parts within the applicable one year period, as set out above, which shall be returned by the owner or any Krause authorized dealer to the factory and which upon examination shall disclose to Krause's satisfaction to be defective.

Krause may, at its option, elect to grant adjustments in the field through an authorized representative and may thereby elect to waive the requirement that parts be returned to Krause's factory.

A new warranty period is not established for replacements. Replacements are warranted for the remaining portion of the one year original warranty period. The repair or replacement of defective parts under this warranty will be made without charge to the owner except for transportation.

Krause does not warrant disc blades, tires, chisel shanks, hydraulic cylinders, accessories and other parts not manufactured by it, but supplied with or as a part of its products. Krause will, however, obtain and pass on any adjustments provided by the manufacturers of such parts under these manufacturer's warranties.

The provisions of this warranty do not apply to any product or parts which have been subject to misuse, negligence or accident, or which have been repaired or altered outside of Krause's factory in any way so as in the judgement of Krause to affect adversely its performance and reliability. Neither does this warranty apply to normal maintenance service and parts, or to normal deterioration due to wear and exposure.

To the extent allowed by applicable law, this warranty is expressly in lieu of other warranties, expressed or implied, in fact or by law, including any implied warranty of merchantability or fitness for a particular purpose. The remedies of repair or replacement as set forth are the only remedies under this warranty. Krause disclaims any obligations or liability for loss of time, inconvenience, commercial loss or direct, consequential, special or incidental damages. This warranty is in lieu of any other obligation or liability of Krause of any nature whatsoever by reason of the manufacture, sale, lease or use of such products and Krause neither assumes, nor authorizes anyone to assume for it, any other obligation or liability in connection with such products.

5650 SERIES FLEX WING FIELD CULTIVATOR DEALER PREDELIVERY CHECK SHEET

TO BE CHECKED BY DEALER

CUSTOMER _____ DATE _____

ADDRESS _____

DEALER _____

ADDRESS _____

MODEL _____ SERIAL NUMBER _____

DEALER CHECK:

1. ___ Check to see that all bolts are tight and pins are in place.
2. ___ Check to see that hydraulic cylinders are full of oil (air bled out of cylinders). Clevis pins with hair pin clips should be in place. The hydraulic system requires 20 gallons of oil.
3. ___ Examine hydraulic hoses to see that they are protected from damage.
4. ___ Bolts attaching the walking tandem to the wheel arms should be tight. Check to see that bearings have been adjusted and greased.
5. ___ Check lug bolts holding wheels to the hub to see that they are torqued from 90 to 95 Ft. Lbs.
6. ___ The correct size tire should be on the implement.
Center Tires: 12.5L x 16, 14-Ply with 56 P.S.I. pressure.
Wing Tires: 9.5L x 15, 8-Ply with 44 P.S.I. pressure.
Gauge Wheel Tires: 9.5L x 15, 8-Ply with 44 P.S.I. pressure.
7. ___ Check to see that pins attaching clevis casting to hitch are in place.
8. ___ Jack should be operational for support of tongue when implement is not attached to a tractor.
9. ___ Wing hinges and wing lift parts are properly secured.
10. ___ Road lock valve was correctly installed and operates satisfactorily.
11. ___ Restrictors are installed in wing lift cylinder rod end ports.
12. ___ All safety decals are in place.
13. ___ Safety Chain is in place.
14. ___ Customer review sheet is filled out and signed.
15. ___ Review lighting requirements. Light Kits are standard.
16. ___ Check to see that the Owner's Manual is in the storage canister.

DELIVERED BY _____

DATE _____

5650 SERIES FLEX WING FIELD CULTIVATOR CUSTOMER REVIEW SHEET

CUSTOMER _____ DATE _____

ADDRESS _____

DEALER _____

ADDRESS _____

MODEL _____ SERIAL NUMBER _____

1. ___ Owner's manual provided.
2. ___ Warranty card filled out and mailed.
3. ___ Review safety warnings and cautions as listed in this owner's manual.
4. ___ Review recommended maximum road speed, width, and height for implement.
5. ___ Review field operational speeds, horsepower, depth and rock conditions.
6. ___ Demonstrate the proper use of road lock valve.
7. ___ Explain the hydraulic depth control system (See page O6).
8. ___ Review limitations of additional weight and transport speed when adding attachments.
9. ___ Explain the importance of maintaining the tools through lubrication, checking that bolts are kept tight, and replacement of worn or broken parts.
10. ___ Recommend that a safety chain be used with the implement.
11. ___ Check wheel lug bolts frequently until they become set.
12. ___ Review lighting requirements for your area.

DEALER _____ DATE _____

CUSTOMER _____ DATE _____

Table of Contents

Rev. 8/97

WARRANTY			
DEALER PREDELIVERY CHECK SHEET	1	STUB SHANK EXT. & FRONT SHANK EXT.	P19
CUSTOMER REVIEW SHEET	2	GAUGE WHEEL ASSEMBLY	P21
TABLE OF CONTENTS	3	HYDRAULIC HOSE ASSEMBLIES W/PLASTIC GRIPS	P22
SPECIFICATIONS	4	WHEELS/TIRES, SFTY. CHAIN, JACK/REAR STAND	P23
<u>OPERATION SECTION</u>		2-PIECE K-TINE SHANK ASSEMBLY	P25
SAFETY FIRST	01	SPRING SHANK ASSEMBLY	P27
ABOUT YOUR FIELD CULTIVATOR	02	HYDRAULIC HOSE GROUP	P29
PREPARING FOR OPERATION	02	HYDRAULIC CYLINDERS:	
PREPARING THE TRACTOR	03	4" x 40" Prince Cylinder Assembly Side Port	P30
HYDRAULIC SYSTEM	03	5" x 16" Prince Cylinder Assembly	P31
HITCHING & UNHITCHING	03	3-1/2" x 12" Eaton Series Cylinder Assembly	P32
Hitching To The Tractor	03	3-3/4" x 12" Eaton Series Cylinder Assembly	P33
Unhitching From The Tractor	03	4" x 12" Eaton Hydraulic Series Cylinder Assembly	P34
TRANSPORTING	04	DECALS & LIGHT KIT	P35
Transport Lock Valve	04	TRAIL HITCH ASSEMBLY	P36
Raising The Wings	05	<u>ASSEMBLY SECTION</u>	
Lowering The Wings	05	WARNING Avoid Bodily Injury	A1
Transport Safety	05	SAFETY & ASSEMBLY AREA INFORMATION	A3
Hitch Pin	06	PART LOCATIONS	A3
FIELD ADJUSTMENTS	06	MODEL NUMBERS	A3
Leveling The Frames	06	ASSEMBLY STEPS	A3
Changing Field Depth	07	MAIN FRAME, FRONT MAIN FRAME	A4
Understanding Your Rephasing System	08	TONGUE	A5
Flexibility	08	TONGUE BRACE	A6
Turning In The Field	09	HINGES	A6
Field Speed	09	LEVELING TUBE BRACKET	A7
GENERAL INFORMATION	09	CENTER WHEELS & TIRES	A7
SERVICING		CYLINDER ANCHOR PLATES & WING STOP TUBES	A8
General Maintenance	010	WING HINGES	A8
Lubrication	010	EXTENSION BAR	A9
Wheel Bearings	010	WING STOPS	A10
Walking Beam Maintenance	010	LEVELING TUBE & CRANK	A11
Spring Shank Repair	011	WING WALKING BEAMS	A11
Hydraulics	012	OUTER WINGS	A12
Avoid Heating Near Pressurized Fluid Lines	012	INSIDE & OUTSIDE WING HINGES	A13
Storage	012	WING FRAME SUPPORT	A13
Repair Parts	012	OUTSIDE LEVELING CRANKS & WALKING BEAMS	A13
SUGGESTED REMEDIES SECTION	013 - 015	FRONT GAUGE WHEELS	A14
<u>PARTS SECTION</u>		SHANK MOUNTING	A14
MAIN FRAME	P2	SHANK MOUNTING CLAMP	A15
MAIN FRAME ROCKER SHAFT	P3	SHANK EXTENSIONS	A15
HITCH FRAME, BRACKET & FRONT MAIN FRAME	P5	TONGUE JACK & SMV EMBLEM	A16
MAIN FRAME & WING TURNBUCKLE ASSEMBLY	P7	HYDRAULICS (CENTER SECTION)	A16
CENTER WALKING BEAM ASSEMBLY	P9	INSIDE WING LIFT HYDRAULICS	A17
MAIN FRAME WING STOP ASSEMBLY	P10	OUTSIDE WING LIFT HYDRAULICS	A18
HINGE ASSEMBLY	P11	DEPTH CONTROL HYDRAULICS	A19
INNER WING LIFT ASSEMBLY	P12	TRANSPORT LOCK VALVE	A20
FRONT INNER WING FRAME	P13	HYDRAULIC SAFETY	A21
WING ROCKER & WALKING BEAM ASSEMBLY	P15	LIGHT KIT & FINAL CHECK	A22
OUTER WING EXTENSION	P16	MODEL 5648 PLACEMENT 6" & 9" Spacing	A23
180° FOLD HINGE ASSEMBLY	P17	MODEL 5654 PLACEMENT 6" & 9" Spacing	A25 - A26
FRONT HINGE ASSEMBLY	P18	MODEL 5655 PLACEMENT 6" & 9" Spacing	A27 - A28
		MODEL 5660 PLACEMENT 6" & 9" Spacing	A29 - A30

5650 5-SECTION FIELD CULTIVATOR SPECIFICATIONS

Rev.6/96

MODEL	SHANK SPACING	NUMBER OF SHANKS	TOTAL CUT WIDTH
5648	9"	63	47' - 3"
		67	50' - 3"
5648	6"	95	47' - 6"
		99	49' - 6"
5654 & 5655	9"	71	53' - 3"
		75	56' - 6"
5654 & 5655	6"	107	53' - 6"
		111	55' - 6"
5660	9"	79	59' - 3"
		83	62' - 3"
5660	6"	119	59' - 6"
		123	61' - 6"

1. SHANKS: 25" Two Piece K-Tine, or 25" Spring Cushion.
2. SPACING: 9" or 6"
3. TIRES & WHEELS:
 - 12.5L x 16, 14-Ply Duals (4) on Center Section
 - 9.5L x 15, 8-Ply Duals (8) on Wings
 - 9.5L x 15, 8-Ply (2) on Gauge Wheels (4) Optional
4. HYDRAULICS:

Depth Control	12" Stroke	Rephasing Cylinder
Inside Wing	4" x 40"	Cylinder
Outside Wing	5" x 16"	Cylinder

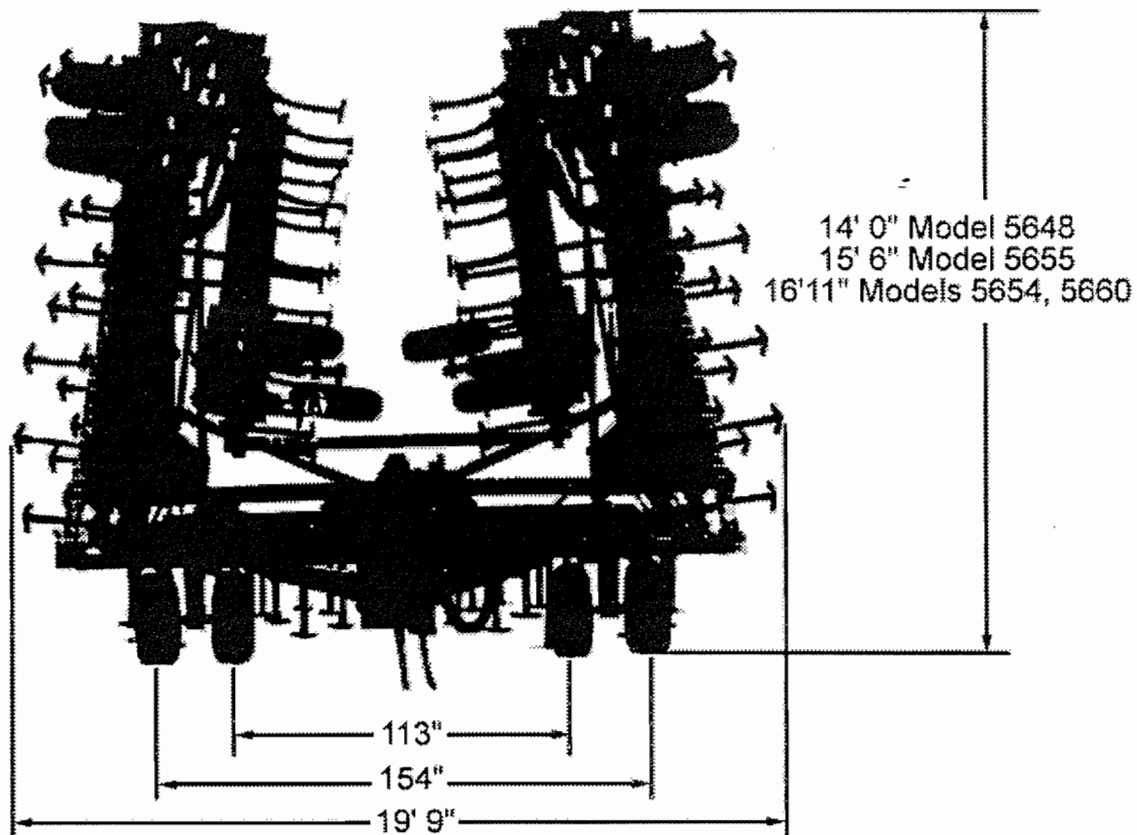

OPERATING SECTION

SAFETY ALERT SYMBOL



BE ALERT TO THE POSSIBILITY OF PERSONAL INJURY.
THIS SYMBOL IDENTIFIES IMPORTANT SAFETY MESSAGES.
CAREFULLY READ THE MESSAGE THAT FOLLOWS.

TEN MOST COMMON HAND SIGNALS USED IN THE FIELD

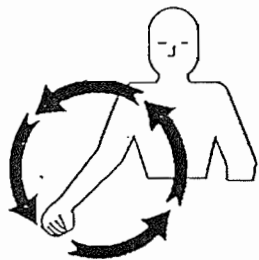

START
THE
ENGINE

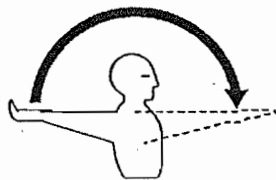

MOVE OUT
OR
TAKE OFF

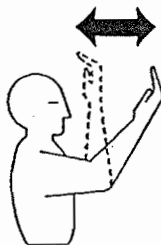

MOVE
TOWARD
ME

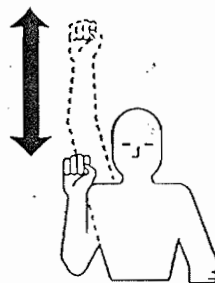

SPEED
IT UP

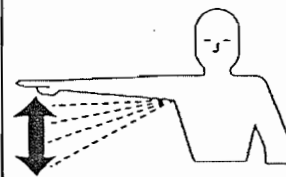

SLOW IT
DOWN



THIS FAR
TO GO



STOP



RAISE
THE
EQUIPMENT

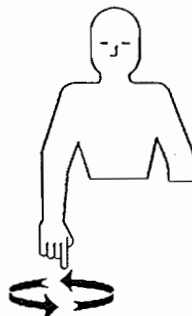

LOWER
THE
EQUIPMENT

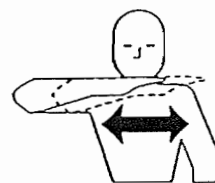

STOP
THE
ENGINE

SAFETY FIRST



WATCH FOR THIS SYMBOL AND CAREFULLY READ THE MESSAGES.

1. **UNDERSTAND SIGNAL WORDS.** A signal word — **DANGER**, **WARNING**, or **CAUTION** is used with the safety alert symbol. **DANGER** identifies the most serious hazards.

DANGER or WARNING safety signs are located near specific hazards. General precautions are listed on CAUTION safety signs. CAUTION also calls attention to safety messages in this manual.
2. Read and understand this owner's manual before operating the cultivator.
3. Be sure that the safety decals and reflectors are clean and in place.
4. Do not climb or walk on cultivator frame, or tires.
5. Never position yourself under any portion of the implement unless the transport lock valve is closed, and the rear jack stands are down supporting the unit, or the entire unit is lowered to the ground.
6. Stop tractor engine and set parking brake before leaving operator's position to adjust, lubricate, clean or unclog the machine.
7. Do not stand between the implement and the tractor unless the tractor brakes are locked and the engine is shut off.
8. Do not stand on or straddle a tongue when unhitching.
9. Never operate unit until hydraulic cylinders and lines are full of oil and free of air. See operating instructions.
10. Use a Slow-Moving-Vehicle (SMV) emblem and proper lighting when transporting the cultivator.
11. Always use a safety chain of tensile strength equal to the gross weight of the cultivator plus any attachments when transporting.
12. Check wheel bolt before and during transport.
13. Always use road locks to hold cultivator in the raised position.
14. Do not road an implement over 15 miles per hour on the best surface conditions. Reduce speed when going up or down hills and when approaching ditches or corners.
15. Check condition of hitch pins and bolts, tires and hubs, and safety chain before transporting.

OPERATING INSTRUCTIONS

Elimination of the hazards listed in this manual should not be construed as providing guarantees that the equipment will meet or exceed all standards or regulations, or will be completely safe to all personnel. The operator should inspect and review the implement after it is in his possession for adequacy in safety for the function for which it will be used.



READ ALL THE SAFETY DECALS ON THE IMPLEMENT AND REVIEW THE SAFETY FIRST SUGGESTIONS ON THE BACK OF THIS MANUAL TO REFRESH YOUR MEMORY. WATCH FOR THE SAFETY SYMBOL, AND READ THE INFORMATION THAT FOLLOWS. THIS IS FOR YOUR OWN PROTECTION.

ABOUT YOUR FIELD CULTIVATOR

This field cultivator has been designed for secondary tillage and is flexible enough to follow the contours of most field conditions.

It is designed to be used for control of weeds, volunteer plants, erosion control, chemical incorporation, and seed bed preparation. The field cultivator works best at speeds of 5 to 6-1/2 M.P.H., however, rocky conditions may require a slower field speed.

Horsepower requirements generally will be 2.5 drawbar horsepower, or 3.25 engine horsepower per shank.

Adding attachments should be limited to KRAUSE original equipment options, or light duty tine or spike harrows that weigh no more than 30 pounds per foot of cut. Additions of harrows will make the field cultivator "tail heavy" and the two rear parking stands should be used when the cultivator is parked or stored. (See "Hitching and Unhitching")

PREPARING THE FIELD CULTIVATOR FOR OPERATION

1. The wings should be down, the road lock valve is in the "closed" position, the jack supporting the tongue, and the hydraulic cylinders pinned and full of hydraulic oil.
2. Check for loose bolts and tighten if needed. Check again for loose bolts after the first half day of operation.
3. Check the shank locations with the Placement Drawings at the back of this manual for the model being used to be sure that the unit has been set up properly.
4. Check tire pressure. Inflate 9.5L x 15, 8-Ply tires to 44 PSI and 12.5L x 16, 14-Ply tires to 56 PSI.



Caution: Check to see that the wheel lug bolts are torqued from 90 to 95 Ft. Lbs. The bolts may work loose, resulting in the loss of a wheel, and subsequent loss of control of the tool / tractor. Check again after the first 1/2 mile of initial transport.

5. Make sure that all grease zerk locations have been sufficiently greased. Grease zerks will be found on rocker shaft bearings, depth stop assemblies, walking tandem beams, and wheel hubs. USE EXTREME CAUTION WHEN WORKING AROUND SHARP SHANK POINTS & SWEEPS.
6. Check and adjust tightness of wheel bearings before operation, after the first week and periodically thereafter. (See *Service Section of this book*)

PREPARING THE TRACTOR

Read your tractor owner's manual. It will describe safe methods of operation. Make sure your tractor has proper added ballast, and that its hydraulic system is full of oil and working properly. Check tractor brakes and warning lights, make sure they are in working order.

HYDRAULIC SYSTEM

Inspect the hydraulic system for tell-tale leaks and loose fittings. Tighten if needed. When assembling your hydraulic system, the JIC and O-Ring fittings and hoses are used making the tape or liquid sealers unnecessary. **MAKE SURE** a restrictor (YELLOW COLOR) is installed in the rod end ports of the inside wing lift cylinders, and each port of outside wing lift cylinders. If not previously filled, your hydraulic system will require 20 gallons of your tractor manufacturer's recommended oil. Read the Service Section "HYDRAULICS" on page O12 before filling your hydraulic system.

When working with rephasing rocker cylinders, be sure all of the cylinders are mounted in proper sequence. Hoses must be attached in the proper order, and all air bled from the hoses and cylinders. See page O8 under REPHASING CYLINDER SYSTEM. If, after some time, one cylinder of the series should start to close for no apparent reason, oil is probably leaking past the O-Rings and an O-Ring kit, available from Krause, should be installed.

REPAIR OF HYDRAULIC CYLINDERS SHOULD BE MADE BY AN AUTHORIZED KRAUSE DEALER ONLY.

A HYDRAULIC HOSE AND CYLINDER SCHEMATIC CAN BE FOUND FOR EACH MODEL IN THIS SERIES ON PAGES P28 AND P29 OF THE PARTS SECTION.

 **Caution:** Air in hydraulic system could allow field cultivator or wings to drop suddenly.

Do not operate the wing hydraulics until you have read wing lift operating instructions under "Transporting".

HITCHING & UNHITCHING

 **Danger:** Do not allow any person to stand between the tractor and implement while backing into position. Sudden loss of control could cause serious injury or death to a person caught between the tractor and implement. Tell your helper to wait until you give him the signal that the tractor is in park or neutral and the hand brake is set and engine is shut off.

Hitching To The Tractor

1. The cultivator should be supported by the tongue jack.
2. Unpin tractor drawbar so it can be moved from side to side.
3. Back the tractor to the field cultivator.
4. Attach clevis to tractor drawbar with a clevis pin that fits the hole size in the tractor drawbar. Make sure the clevis pin is locked or bolted in place to prevent loss.

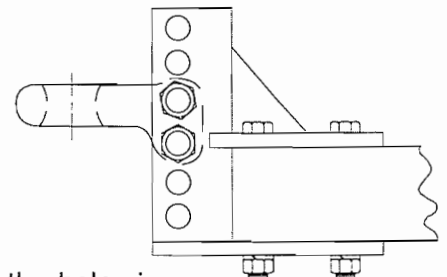

5. Fasten safety chain and lights. (See "Transporting")
6. Place tongue jack in storage position.
7. Connect hydraulic hoses to tractor.
8. Raise the cultivator and make sure the transport lock valve is in the closed position (see page O4)

Unhitching From The Tractor

Find a level place to park. If the field cultivator is to remain parked for storage over a long period of time, be sure to read storage suggestions on page O12.

1. To unhitch the tractor from the field cultivator, place the tractor in park or neutral and set the hand brake. If you are not parking on level ground block the implement tires.
2. Raise the unit up and close the lock valve. Turn off the tractor engine and relieve the hydraulic pressure.
3. Lower stands (A) until stand contacts ground and pin in support position. Lower machine until firmly supported by storage stands.
4. Disconnect the hydraulic hoses, safety chain, and lights, and the tractor may be moved away.

⚠ Caution: Tongue can whip upwards and cause injury when hitch pin is removed. Lower storage stands and pin in support position before removing hitch pin.

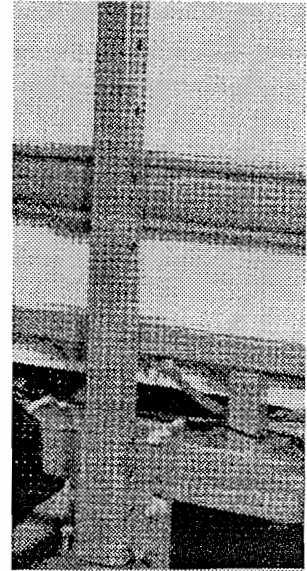

TRANSPORTING

Check specification pages and be aware of transport height and width of your model of field cultivator.

⚠ Warning: Always close transport lock valve when transporting to prevent unit from falling due to hydraulic failure, or accidental activation of the operator's control. Lowering of the tool during transporting could result in loss of control of implement and / or tractor. The tractor drawbar must always be pinned for transport.

Transport Lock Valve

1. With the cultivator in the fully raised position, close the TRANSPORT LOCK VALVE.

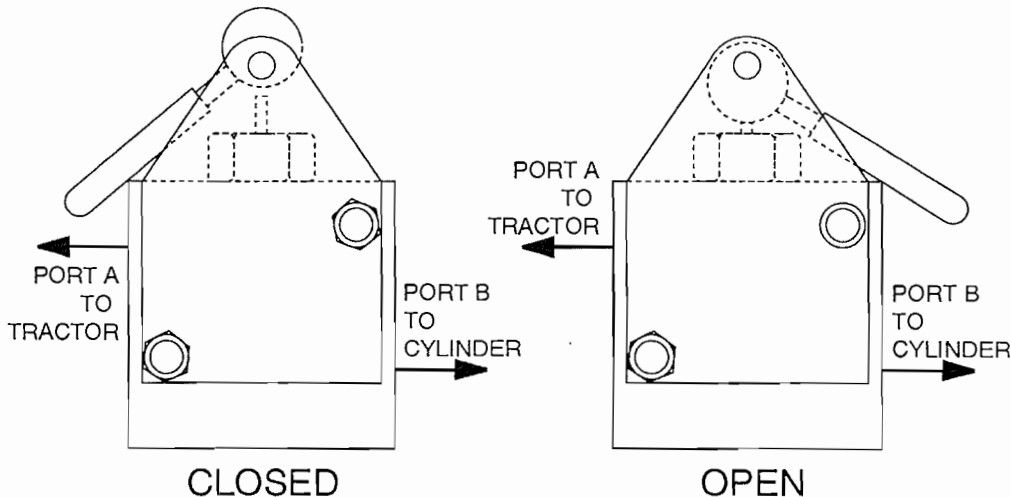

PHOTO 38

Raising The Wings

The field cultivator should be in the raised position with lock valve closed. Retract wing cylinders slowly until wings are completely raised and cylinders are fully closed.

Warning: Always stand clear of wings when they are in raised position. A hydraulic failure or activation of hydraulic controls by someone could result in serious injury to anyone under the wings.

Be aware of shanks and attachments when working the unit with the wings raised. Serious head injury can result from walking into shank shovels or tines on attachments.

Lowering The Wings

Clear the area of all persons and obstructions. Slowly extend wing cylinders, watching carefully that hydraulic hoses and attachments are free. Hold tractor valve open until cylinders are fully extended.

IMPORTANT: KEEP ROAD LOCK DECALS AND STAND CLEAR OF WING DECALS CLEAN AND IN PLACE AT ALL TIMES. DECALS MUST BE REPLACED IF THEY ARE DESTROYED, MISSING OR HAVE BEEN PAINTED OVER.

Transport Safety

Warning: Always use a safety chain with tensile strength equal to the gross weight of the unit, plus any attachments, when transporting.

Use the ASAE Slow Moving Vehicle (SMV) emblem. The emblem is to mounted point up in a plane that is perpendicular to the direction of travel $\pm 10^\circ$.

It shall be placed centrally at the rear of the vehicle, unobscured, and 2' to 6' (0.61 to 1.8m) above the ground, measured from the lower edge of the emblem. The SMV emblem should be wiped clean before entering the road or highways.

Comply with state and local laws pertaining to lighting and road widths. Turn on flashing lights whenever traveling on a highway except where it is prohibited by law. If the implement obscures the tractor warning lamp, a lamp must be added to the left of the implement. Transport during daylight hours only. Watch your clearance. Be aware of obstacles along the side of the roadway that might be caught by the field cultivator when passing by. Pull over to the side of the road to permit safe clearance for oncoming traffic. Keep the red and yellow reflectors clean and visible. Replace the reflectors if they become faded or damaged. Watch for pedestrians on the side of the road that need to be warned of your presence.

Danger: Always check conditions of transport lock valve, tires, wheels, hubs, safety chain, hitch bolts, and clevis pin before transporting the implement.

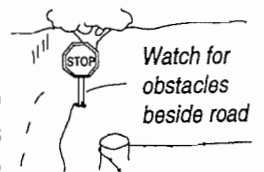
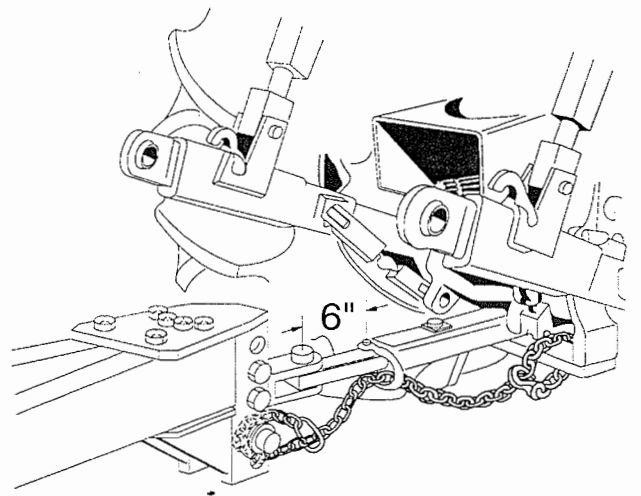

Be aware of the transport height as well as the width of your model of field cultivator. Care should be taken not to snag low hanging telephone lines or electrical service lines.

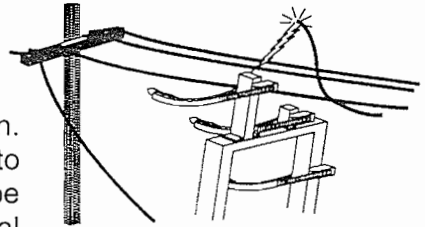

It is best to use a tractor to transport the cultivator to another location. If using another type of towing unit it should never be allowed to exceed 15 M.P.H., since implement tires are not constructed to be operated at higher speeds. The towing vehicle should always equal or exceed the gross weight of the cultivator and attachments.

Always check the tire pressure before transporting and look for damaged tires. Wobble the tires from side to side. If excessive play is noted, adjust the hub spindle nut before transporting to prevent damage to the hub or bearings.

⚠ Caution: It is very important to check wheel lug bolts after the first half mile of initial transport (delivery). If loose, tighten to 90 to 95 Ft. Lbs. torque. Continue to check frequently until they remain firmly seated.

Hitch Pin

Use the proper size hitch pin with a means for holding it in place so it cannot work itself out during transport. The hitch pin should be inspected for wear or cracks before using it to transport your field cultivator.

FIELD ADJUSTMENTS

Leveling The Frames

To operate your cultivator most efficiently, it must be worked level. This is best accomplished by following these steps:

- Step 1. Raise the cultivator out of the ground to relieve depth stop pressure.
- Find a fairly level piece of ground and lower the cultivator down onto the sweeps.
 - Fully retract the rocker cylinders.
 - Rotate each depth crank clockwise until the crank begins to carry some load then stop. At this point the cultivator is set at **approximately 2" of depth.**
 - Two full turns of the crank counter-clockwise  will increase depth about 1/2". Five full turns counter-clockwise will increase depth 1".

PHOTO 37



Step 2. Front To Rear Leveling In The Field

- Lower cultivator into the ground until the rocker cylinders are fully retracted and the cultivator is operating at the pre-set depth.
- Stop the tractor with the cultivator still in the ground.
- Stand at one side of the cultivator at a reasonable distance away and view the frame from front to back. If the frame is not level, adjust the hitch clevis up or down to a better location. The jack will aid in making this adjustment.

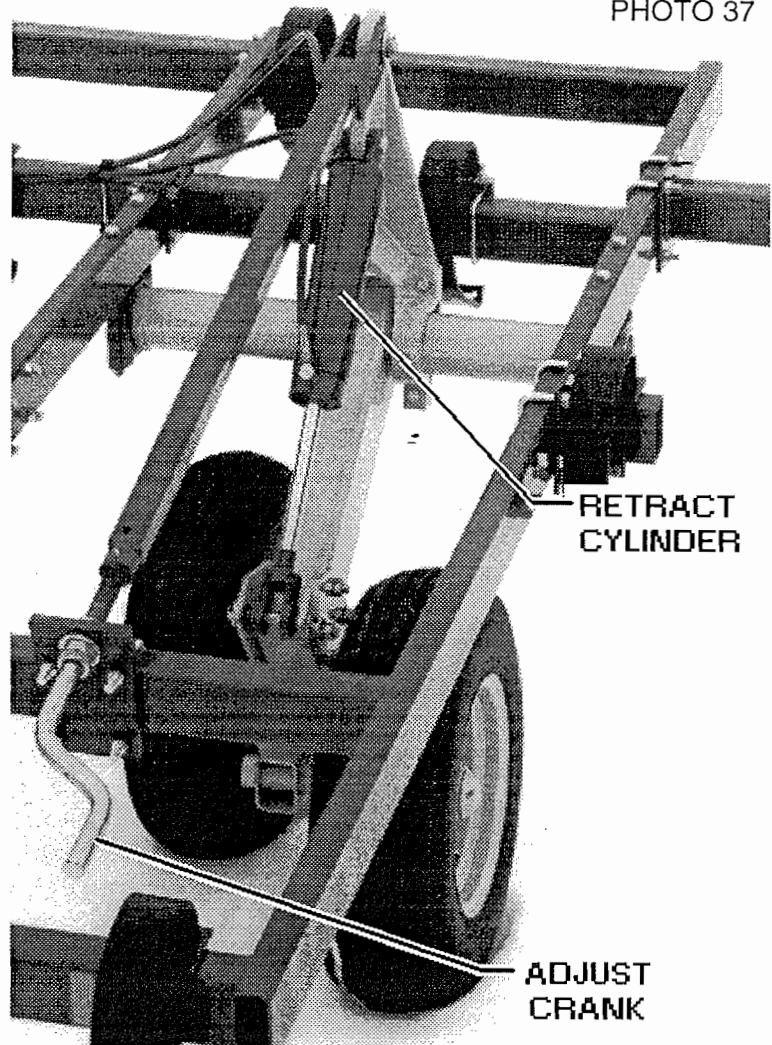
NOTE: The DUCTILE HITCH CASTING can be rotated upside down for fine increment tongue height adjustment.

- To adjust clevis, raise cultivator out of the ground. Lower the rear jack stands. Lower the cultivator until some weight is on the rear jack stands. **Close the transport lock valve.** You may now use the tongue jack to raise or lower the tongue height.

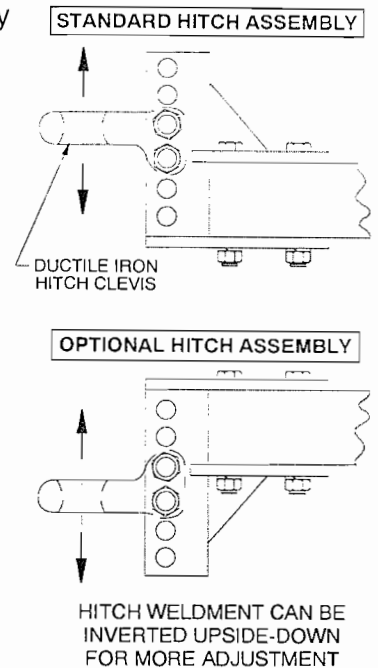

Step 3. Side To Side Leveling In The Field

- With the cultivator stopped in the ground, view the cultivator from behind.
- Note how much higher or lower each wing is, if any.
- Raise the cultivator out of the ground and then lower it back down on the sweeps. Fully retract the rocker cylinders.
- Rotate the wing crank counter-clockwise to increase the depth or clockwise to decrease the depth. A 1" depth change requires 5 turns.
- Pull the cultivator forward and recheck Steps 2 and 3.

Changing Field Depth

Set cultivator at proper operating depth.

IMPORTANT: IF STABILIZER WHEELS ARE ADJUSTED WITH TOO MUCH DOWN-PRESSURE, DAMAGE TO THE STABILIZER WHEEL ASSEMBLY AND/OR FRAME CAN RESULT. ALWAYS ADJUST STABILIZER WHEEL FOR ONLY LIGHT CONTACT WITH THE SOIL AT OPERATING DEPTH.

PROCEDURE TO CHANGE DEPTH:		DEPTH CRANK ROTATION		APPROX. CHANGE IN DEPTH	NUMBER OF TURNS
1.	Raise the cultivator out of the ground.			1/2"	2
2.	Lower cultivator down onto the ground and fully retract rocker cylinders.			1"	5
3.	Rotate all depth cranks the same number of times.			1-1/2"	7
				2"	10
IMPORTANT: Damage to the center rocker shaft may occur if both cranks are not adjusted the same.					

74-394

Understanding Your Rephasing Cylinder System.

When the cultivator is raised completely out of the ground these specially designed cylinders are rephased for uniform lifting by holding the tractor remote hydraulic control lever in the raised position for 20 to 30 seconds. This allows a small volume of oil to bypass the piston seals. Consequently, all of the cylinders can be fully extended.

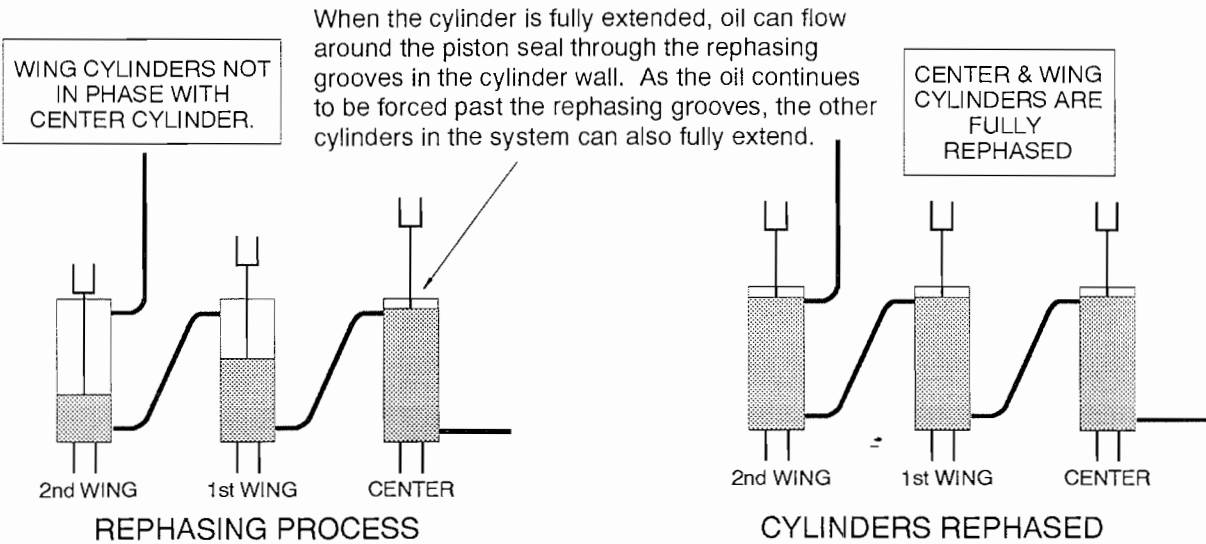
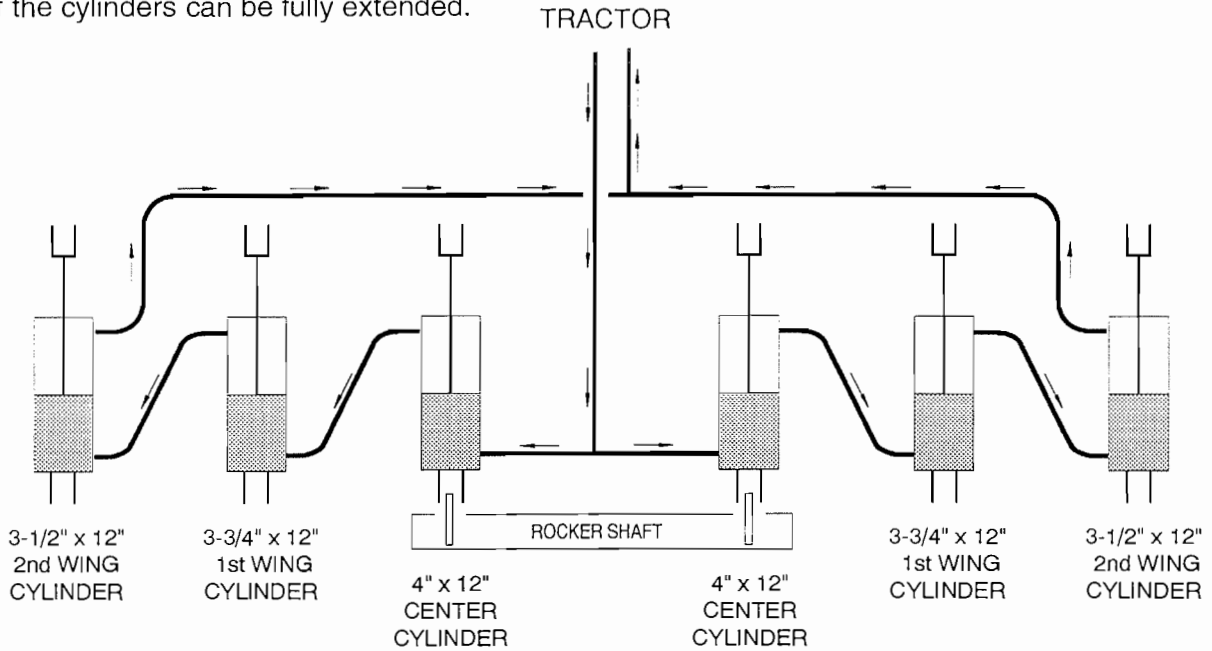

When the cylinder is fully extended, oil can flow around the piston seal through the rephasing grooves in the cylinder wall. As the oil continues to be forced past the rephasing grooves, the other cylinders in the system can also fully extend.

Flexibility

ALWAYS WORK WITH THE WINGS DOWN: Major damage may occur to shanks and frame members if used with the wings up. For maximum flexibility, make sure the wing hydraulic cylinders are fully extended after the wings are down.

When working terraced ground, place the wing up on the terrace, not down over the terrace, as the wing is limited in its downward movement, but not as much in its upward movement.

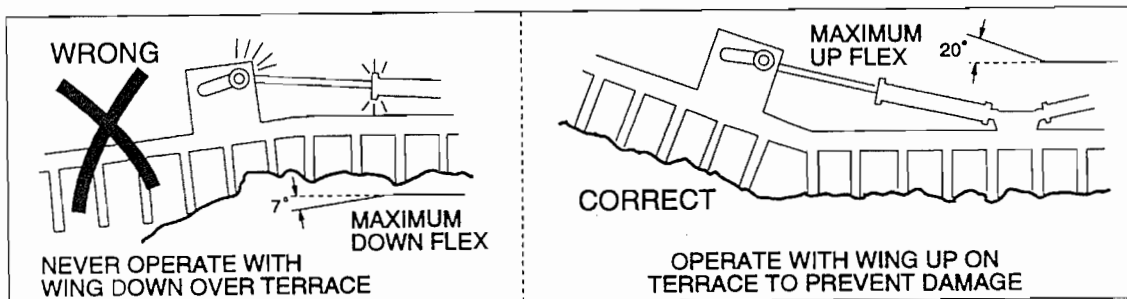

Turning in The Field

Short turns at working depth may result in driving the outside shanks deeper in the ground, causing damage to shanks or frame members. If making short turns, raise the field cultivator out of the ground and complete the turn before engaging the tool for further tilling.

When lifting the field cultivator completely out of the ground, hold the tractor hydraulic valve open for a second or two to resynchronize the slave cylinders.

See section "UNDERSTANDING YOUR REPHASING CYLINDER SYSTEM" on page O8 .

Field Speed

While high field speed of around 6-1/2 M.P.H. may be recommended for weed killing purposes in light soil and shallow depth, a slower speed is recommended for heavy soils and deep work. Slower speed will also add life to field cultivator points and sweeps.

GENERAL INFORMATION

Points are recommended for light soils and when higher ridges are desired. Sweeps are for light draft cultivation and not for deep work.

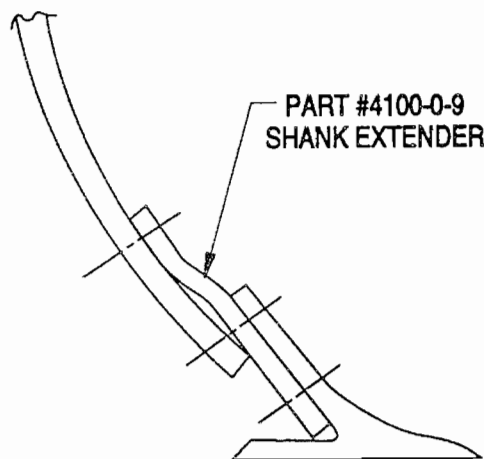

LOWERS DEPTH 1"

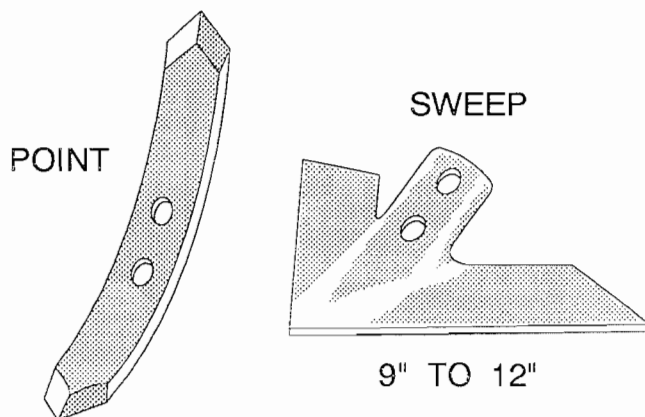

Sweeps with a 47° stem angle are recommended.

Shank Extenders (Part number 4100-0-9) are for use on C-Shanks and K-Tines, located in back of the tractor tires, to lower the depth of the shanks by approximately 1".

⚠ Danger: The wing mounted shanks and points can seriously injure anyone that gets too close. Never under any circumstances should anyone be allowed to walk or work under a wing that is in the raised transport position.

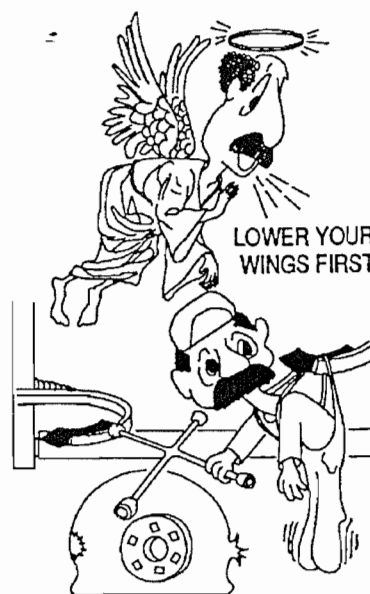

SERVICING

General Maintenance

All nuts should be checked and tightened during and after the first 1/2 day of operation, and periodically thereafter. Keep tires inflated to the recommended pressure, and check the wheel bolts until they are firmly seated. Hydraulic hoses should be checked for wear and pinched areas and replaced if necessary. Check shanks and mountings for breaks and turn or replace points when worn.

NOTE: When turning or replacing points, be sure to turn or replace all of the points.

⚠ Warning: Raise the cultivator and make sure that the lock valve is closed and rear jack stands are lowered before working around or replacing cultivator points or sweeps.

Lubrication



The initial lubrication of all grease fittings will assure long life and satisfactory performance from the field cultivator. Minimum lubrication is required. Use a multi-purpose type grease at all grease zerk locations after each 40 hours of operation. Points of lubrication are: rocker shaft bearings, walking tandem bearings, wheel hubs, and depth stop assemblies.

FOR YOUR SAFETY: WHEN LUBRICATING OR ADJUSTING YOUR FIELD CULTIVATOR, WATCH FOR OBSTRUCTIONS AND PROTRUSIONS. LOWER IMPLEMENT WINGS TO THE GROUND AND ENTER FRAMEWORK BY STEPPING OVER. DO NOT WALK ON TIRES.

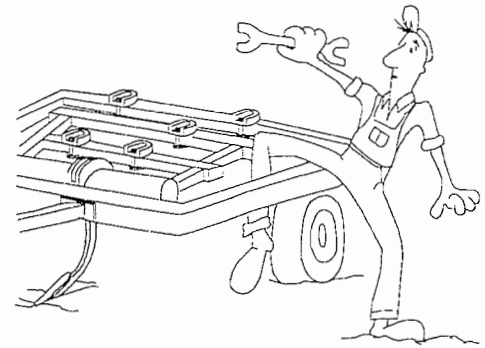

Wheel Bearings

Grease wheel bearings every 24 hours of use. Check for excessive end play each time bearings are greased. Once a year, clean and repack wheel bearings with EP#2 Grease. Replace seals each time bearings are removed. Replace any worn or damaged parts. After repacking, replace hub with seal and rear bearing already assembled. Use light oil on seal surface and use extreme care when pushing seal over the spindle. Install outer bearings, flat washer, and slotted nut. Tighten nut while turning hub until there is resistance to rotation. Then back off nut from 1 to 2 slots until hub turns freely without end play. Secure nut with clinched cotter pin.

Walking Beam Maintenance

Grease walking beam bearings every 24 hours of use. Check, clean, and repack walking beam bearings each year in a procedure similar to that of wheel bearings.

When reassembling the walking beam, tighten the slotted axle nut in until there is a 5 to 10 ft. lb. preload on the bearings. **Do not back the axle nut off.**

Spring Shank Repair

Check shanks periodically for loose bolts and nuts, at this time check for broken springs.

To replace a broken spring, first attach a (Part # 4122-0-14) Winch Bracket to the upper sweep boot, attach a chain to this bracket and around the cultivator frame. Pull up on the shank until the roll pin is free. See Figure 1.

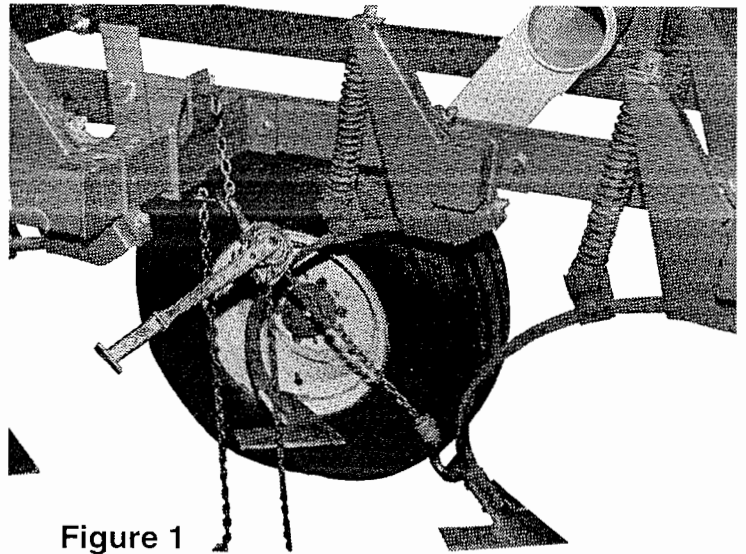

Figure 1

Remove roll pin, lower shank and replace broken spring. See Figure 2.

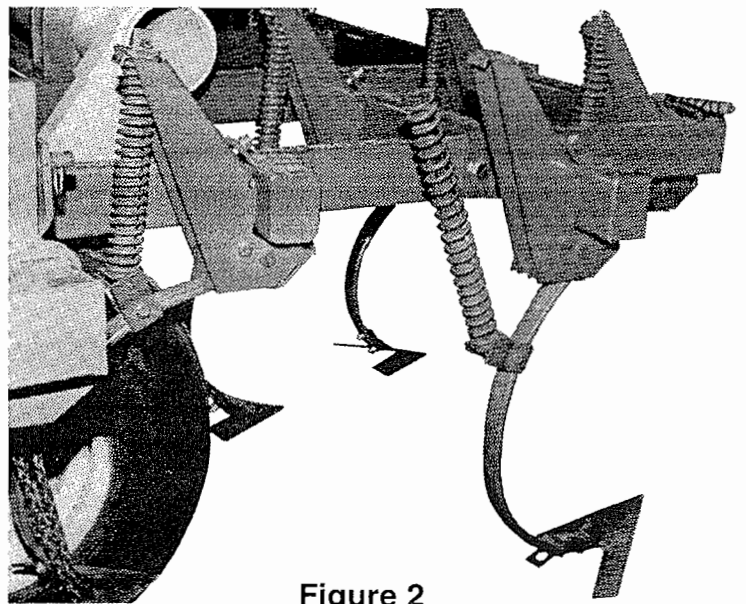

Figure 2

Guide spring rod through slot in the mounting channel with a screwdriver. See Figure 3.

Replace square washer and roll pin. Remove the winch and the 4122-0-14 winch bracket, store bracket on a spring shock clamp bolt.

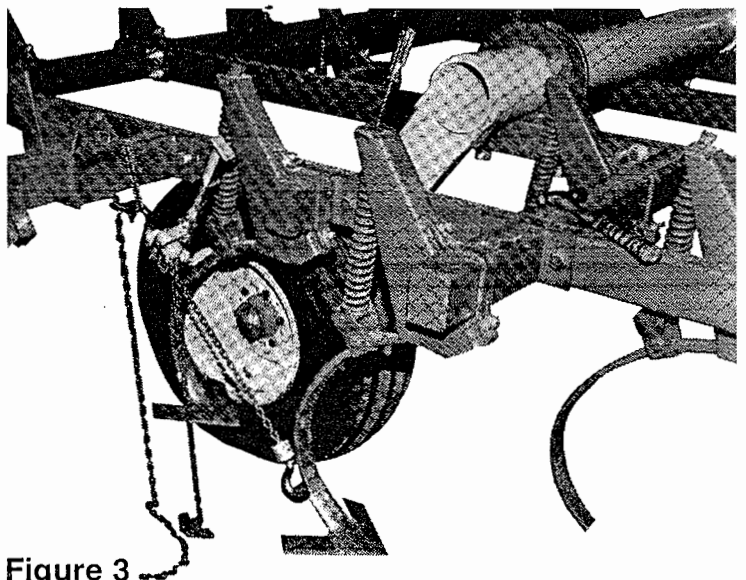

Figure 3

Hydraulics

If the implement wing lift hydraulic system has never been used, stored over a period of time or disassembled for any reason, unpin the rod ends of the cylinders and support the cylinders so the rod ends will clear frame members or lugs when fully extended. Back the tractor to the front of the field cultivator and connect the hydraulic hoses to the tractor. Check the tractor hydraulic reservoir and make sure it is full of the manufacturer's recommended oil. If you are sure the implement hydraulic hose connections are tight, begin filling the system by extending and retracting the cylinders. Hold the control lever open and pause at the end of each stroke of the cycles to bleed the air from the system. Continue the cycles until the cylinders respond with immediate solid actuation. When you are sure the systems are free of air, pin the rod ends of the cylinders to the implement cylinder lugs.

⚠ Warning: Escaping fluid under pressure can penetrate the skin causing serious injury. Avoid the hazard by relieving pressure before disconnecting hydraulic lines. Tighten all connections before applying pressure.

Search for leaks with a piece of cardboard. Protect hands and body from high pressure fluids.

If an accident occurs, see a doctor immediately. Any fluid injected into the skin must be surgically removed within a few hours or gangrene may result.

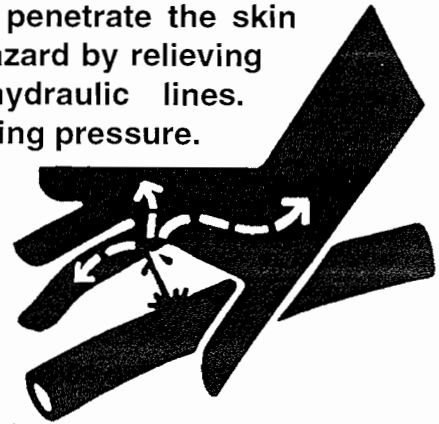

Avoid Heating Near Pressurized Fluid Lines

Flammable spray can be generated by heating near pressurized fluid lines, resulting in severe burns to yourself and bystanders. Do not heat by welding, soldering, or using a torch near pressurized fluid lines or other flammable materials. Pressurized lines can be accidentally cut when heat goes beyond the immediate flame area.

Storage

Select a level area, lower the wings and set the field cultivator down on blocks to prevent points from settling into the ground. Retract the gauge wheel hydraulic cylinder. Coat sweeps and wing lift cylinder rods with rust preventative. Inspect for worn or damaged parts and replace as needed to avoid delays the next season. Check to be sure hydraulic hose couplers are stored on top of the tongue and not left laying on the ground.

Repair Parts

Refer to the Assembly Section of this book when repairing or replacing parts, and follow the same procedure as used when assembling a new unit. Reverse this procedure for disassembly. The Parts Section of this book will show a breakdown of assemblies, location of parts and part numbers.

KRAUSE parts were developed and tested for these units, therefore, it is recommended that KRAUSE replacement parts be used.

⚠ Caution: If replacing hydraulic hose, use only hose that meets or exceeds 3,000 PSI working pressure.

IMPORTANT: REPAIR OF HYDRAULIC CYLINDERS SHOULD BE MADE BY AN AUTHORIZED KRAUSE DEALER ONLY.

⚠ Caution: Explosive separation of a tire and rim parts can cause serious injury or death.

Always maintain the correct tire pressure. Do not inflate the tires above the recommended pressure. Inspect tires and wheels daily. Do not operate with low pressure, cuts, bubbles, damaged rims or missing lug bolts and nuts.

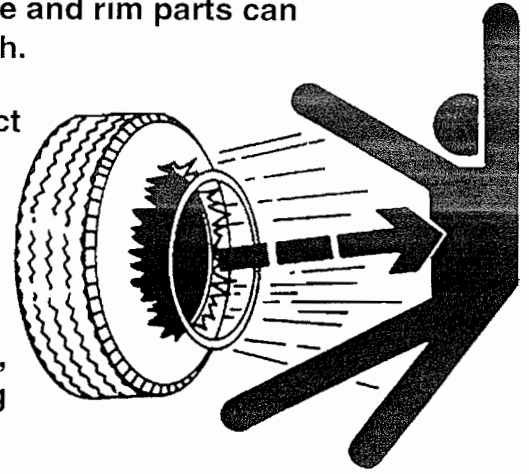

SUGGESTED REMEDIES FOR POSSIBLE FIELD PROBLEMS

PROBLEM	POSSIBLE CAUSE	SUGGESTED REMEDY
Plugging	Straw is dragging	Work deeper
	.. Bunched trash	.. Work shallow the first time
	.. Field is too wet	Allow field to dry
	.. Shanks positioned wrong	Recheck shank spacing
Not level from front to rear	Clevis height not adjusted when depth changed	Use wheels to gauge depth and adjust clevis height with unit in working position
	.. Some weight of unit not on wheels during leveling adjustment	Use wheels to gauge depth and adjust clevis height with unit in working position
Excessive Ridges	Loose point or sweep bolts	Tighten plow bolts or replace if missing
	.. Improper shank spacing or shanks located wrong	Measure and relocate. If shank is shifting on frame, make sure shank is straight front to back when tightening hex nuts
	.. Frame not level	Level frame at operating depth as described in operating instructions
	.. Bent shank	Straighten or replace shank
	.. Sweeps with old residue will cause soil build-up preventing necessary scouring for even flow	Remove trash and residue. Clean field cultivator after operation. Use rust preventative before storing
Field Cultivator will not lower	Road lock valve	Open lock valve
	.. Hose couplers not locked in tractor sockets	Check hydraulic hose connectors
	.. Oil not flowing through system	Plugged line or cylinder
		.. Look for restrictor ell in rocker cylinder plumbing. Replace with STD. 90° ell

PROBLEM	POSSIBLE CAUSE	SUGGESTED REMEDY
----------------	-----------------------	-------------------------

Field Cultivator does not follow directly behind tractor	Points are different length	Replace or turn
	Bent Shanks	Replace or straighten shanks
	Wings out of adjustment	Readjust wing depth stop assemblies. See pages O7 & O8
	Tire size or air pressure	All tires should be within $\pm 1/2$ " diameter
		Match tire pressure with Specifications
	Shank locations wrong	Check shank spacing. Correct if needed
Slave cylinder out of phase	Raise unit out of ground. Hold control lever open until all cylinders are completely extended	

Center section not level from side to side	Incorrect tire pressure	Check tire pressures. 9.5L x 15 8-Ply 44 PSI; 12L x 16, 14-Ply 56 PSI
	Center depth cranks not equally adjusted	There are two depth cranks on the center section that must be adjusted the same on each side.

Wings not level from side to side	Wing too high	To lower, raise and lower cultivator to relieve crank load. Then turn wing crank counter-clockwise
	Wing too low	To raise, raise and lower cultivator to relieve crank load. Then turn crank clockwise
	Wing lift cylinders not fully extended	Extend cylinder to maximum length; hold open briefly
	Slave cylinders out of phase	Raise unit out of ground; hold control lever open until cylinders are completely extended. Hold for 20 seconds.

Wings will not raise to transport position	Wing lift cylinder restrictors plugged	Remove, check & clear any foreign material that might plug small orifice in restrictor at rod end of cylinders
	Insufficient hydraulic pressure	Check tractor hydraulic system

Wheels have excessive wobble	Loose wheel bolts	Torque wheel bolts from 90-95 Ft. Lbs.
	Loose spindle nut	Tighten spindle nut, turn back one notch and pin

Settling or continually going deeper while working	Rocker cylinders not fully retracted	Adjust depth cranks so cylinders are fully retracted at desired working depth
--	--------------------------------------	---

Wings will not flex down	Wing lift cylinders not fully extended	Extend wing lift cylinders to max. length
--------------------------	--	---

PROBLEM	POSSIBLE CAUSE	SUGGESTED REMEDY
----------------	-----------------------	-------------------------

Field cultivator will not penetrate	Sweeps have wrong angle	Use 47° stem angle
	.. Ground is too hard	Wait for moisture
	.. Dull points	Replace or turn over
	.. Excessive field speed	Slow to 5 MPH or less

***IMPORTANT: DO NOT REMOVE SHANKS**

* NOTE: Removing shanks to obtain additional depth will cause the remaining shanks, and frame members on which these shanks are mounted to be overloaded. This could cause bent shanks, broken bolts or clamps, or twisted frame members.



PARTS SECTION

THE FOLLOWING ILLUSTRATED PARTS SECTION HAS BEEN COMPILED TO REFLECT PART NUMBERS REQUIRED TO ORDER PARTS, AND TO SUPPORT THE ASSEMBLY SECTION FOR DIMENSIONS AND DESCRIPTIONS OF ALL PARTS, BOLTS, PINS, ETC. THE OPERATOR CAN ALSO IDENTIFY PART NAMES TO CLARIFY PROPER OPERATIONAL STEPS.

MAIN FRAME AND INSIDE WING FRAME

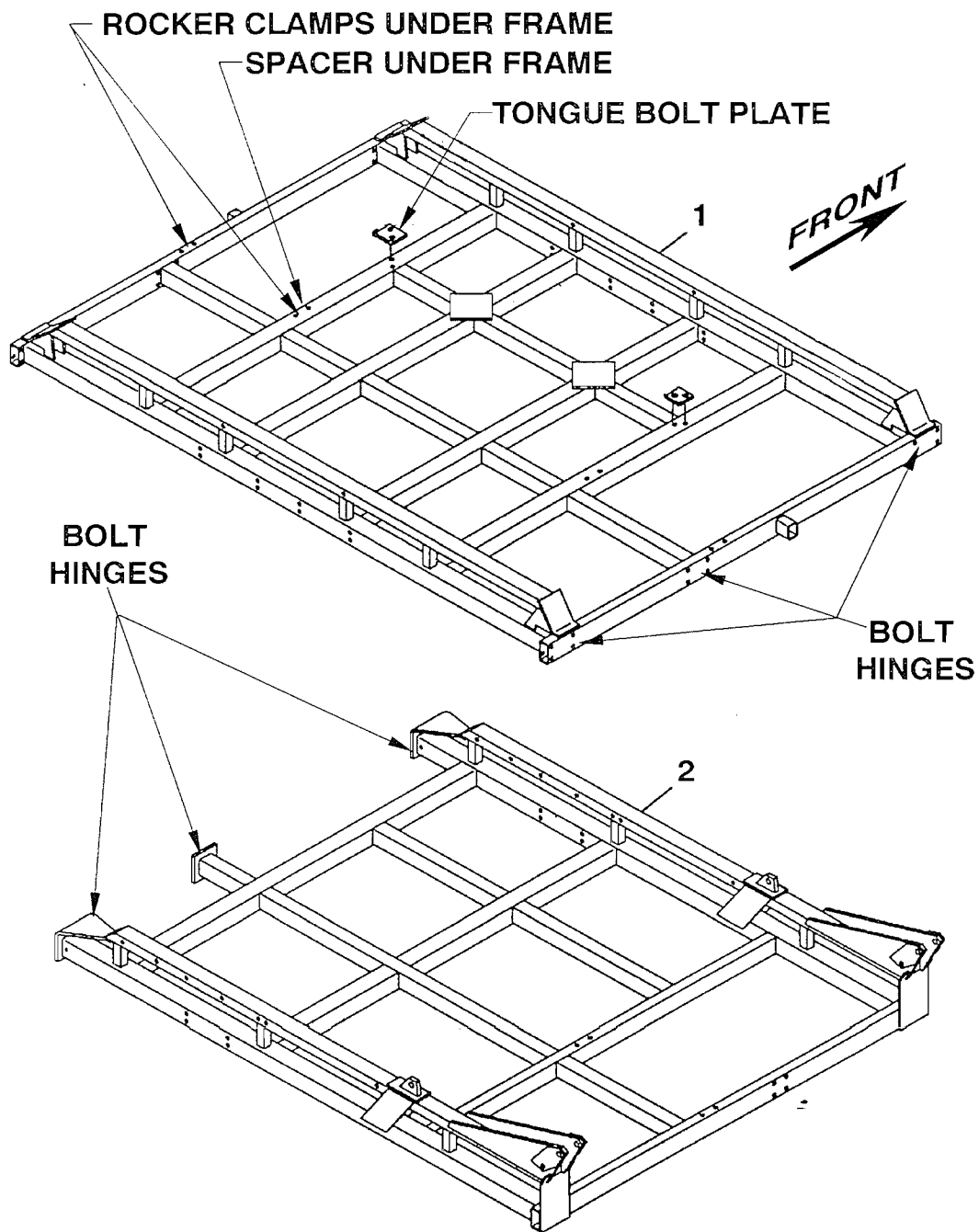

M5650-39

FOR MODELS - ALL

6/96

Item	Part Number	Part Description	Qty.
1	5660-1-0	Main Frame Weldment	1
2	● 5648-20-0	Right Wing Frame Weldment	1
	● 5648-18-0	Left Wing Frame Weldment	1
	■ 5655-20-0	Right Wing Frame Weldment	1
	■ 5655-18-0	Left Wing Frame Weldment	1
	★ 5660-20-0	Right Wing Frame Weldment	1
	★ 5660-18-0	Left Wing Frame Weldment	1

● Used for Model 5648 ONLY

■ Used for Model 5655 ONLY

★ Used for 5654 & 5660 ONLY

MAIN FRAME ROCKER SHAFT

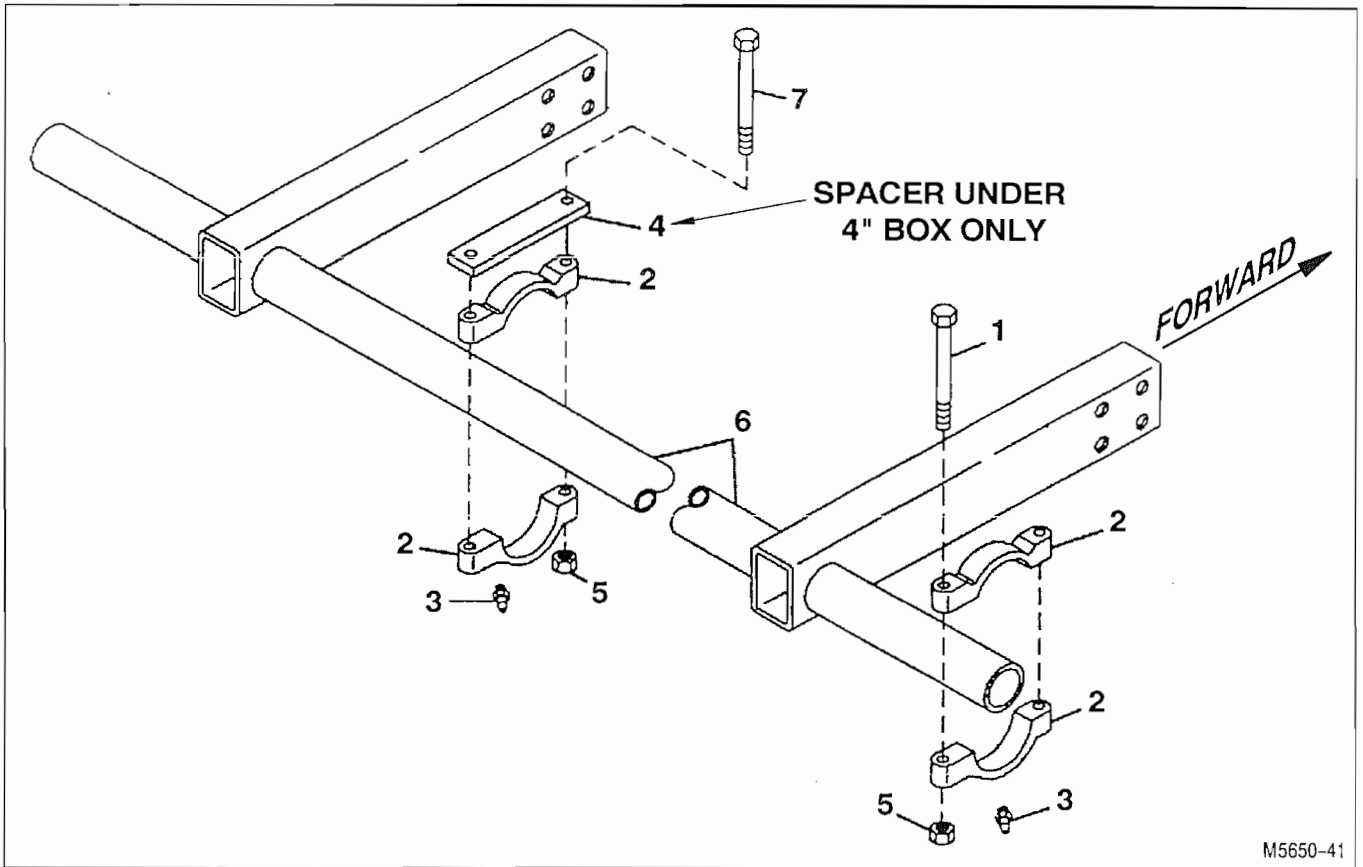

M5650-41

FOR MODELS - ALL

1/93

Item	Part Number	Part Description	Qty.
1	62-619	5/8NC x 11-1/2" GD.5 Cap Screw	4
2	5660-0-13	Bearing	8
3	65-113	1/4-28UNF Zerk	4
4	5660-0-4	Strap	2
5	63-109	5/8NC Hex Nut	8
6	5660-10-0	Main Rocker Shaft Weldment	1
7	62-581	5/8NC x 11" GD.5 Cap Screw	4

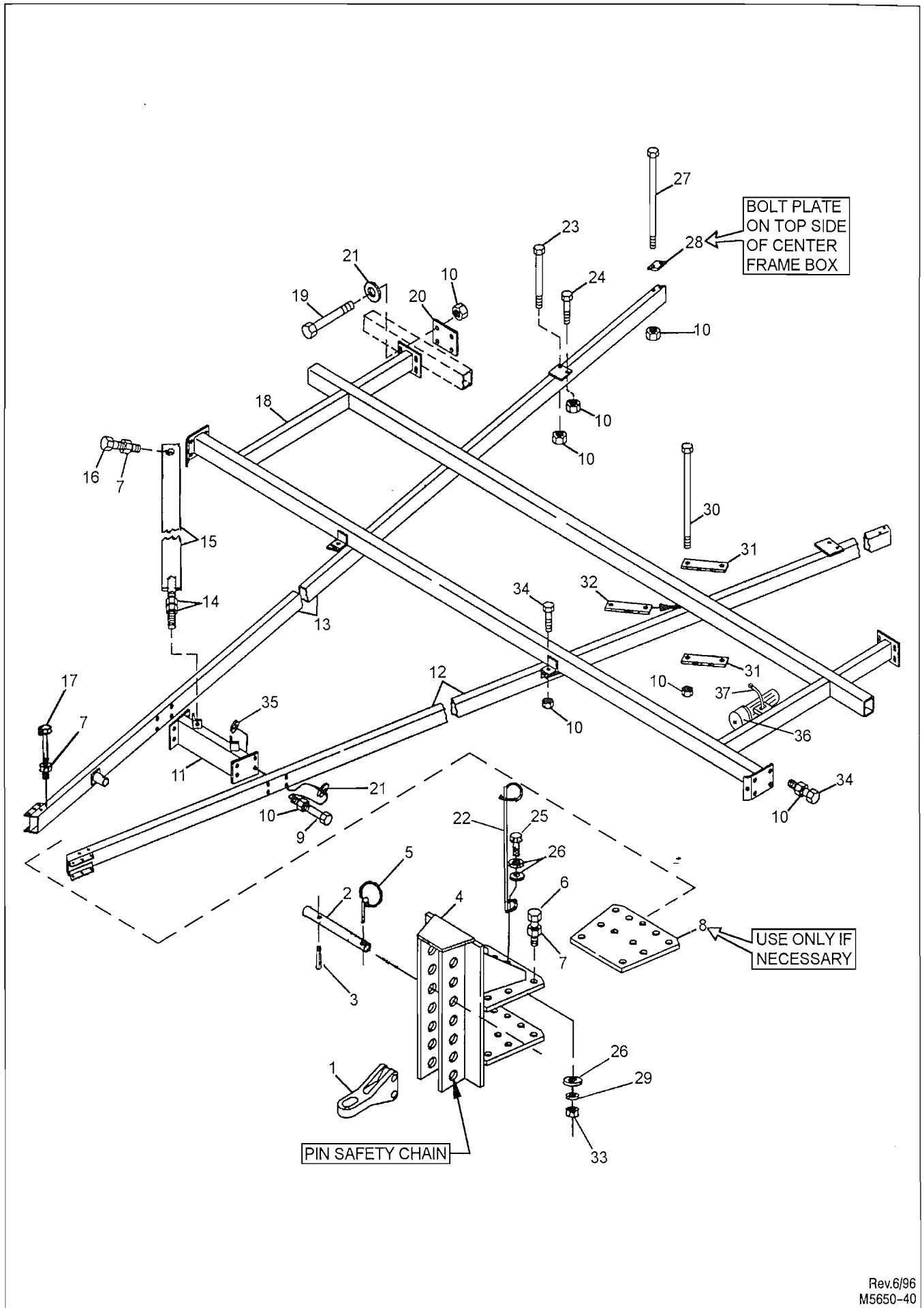

HITCH FRAME, BRACKET AND FRONT MAIN FRAME

FOR MODELS - ALL

6/96

Item	Part Number	Part Description	Qty.
1	5215-0-4007A	Hitch Clevis Casting	1
2	4025-0-3	Hitch Pin	2
3	60-617	3/8" DIA. x 2-1/2" Roll Pin	2
4	5660-30-0	Hitch Bracket Weldment	1
5	60-102	Klick Pin	2
6	62-421	3/4NC x 2" GD.5 Cap Screw	12
7	63-112	3/4NC Hex Nut	18
8	5660-0-10	Hitch Shim (Use as needed)	1
9	62-566	5/8NC x 5-1/2" GD.5 Cap Screw	8
10	63-109	5/8NC Hex Nut	40
11	5660-3-0	Front Tube Weldment	1
12	5660-6-0	Left Tongue Tube Weldment	1
13	5660-5-0	Right Tongue Tube Weldment	1
14	63-171	7/8NC Jam Nut	4
15	5660-29-0	Truss Strap Weldment	2
16	62-195	3/4NC x 2-1/2" GD. 5 Cap Screw	2
17	62-220	3/4NC x 8-1/2" GD.5 Cap Screw	4
18	5660-24-0	Front Main Frame Weldment	1
19	62-439	5/8NC x 5" GD.5 cap Screw	2
20	5648-0-3	Bolt Plate	2
21	64-110	5/8" STD. Flat Washer	16
22	24-100	Hose Stand	1
23	52-433	5/8NC x 7-1/2" GD.5 Cap Screw	2
24	62-441	5/8NC x 2-1/2" GD.5 Cap Screw	2
25	62-343	1/2NC x 2" GD.5 Cap Screw	1
26	64-108	1/2" STD. Flat Washer	3
27	62-582	5/8NC x 12" GD.5 Cap Screw	4
28	5660-0-12	Bolt Plate	2
29	64-107	1/2" STD. Lock Washer	1
30	62-618	5/8NC x 12-1/2" GD.5 Machine Bolt	4
31	5660-0-19	Strap (3/4" x 2-1/2" x 9.20")	4
32	5660-0-1	Strap (3/8" x 2" x 9.20")	1
33	63-106	1/2NC Hex Nut	1
34	62-169	5/8NC x 2" GD.5 Cap Screw	12
35	64-109	5/8" STD. Lock Washer	8
36	99-192	Owner's Manual Storage Canister	1
37	25-1163	Hose Clamp	1

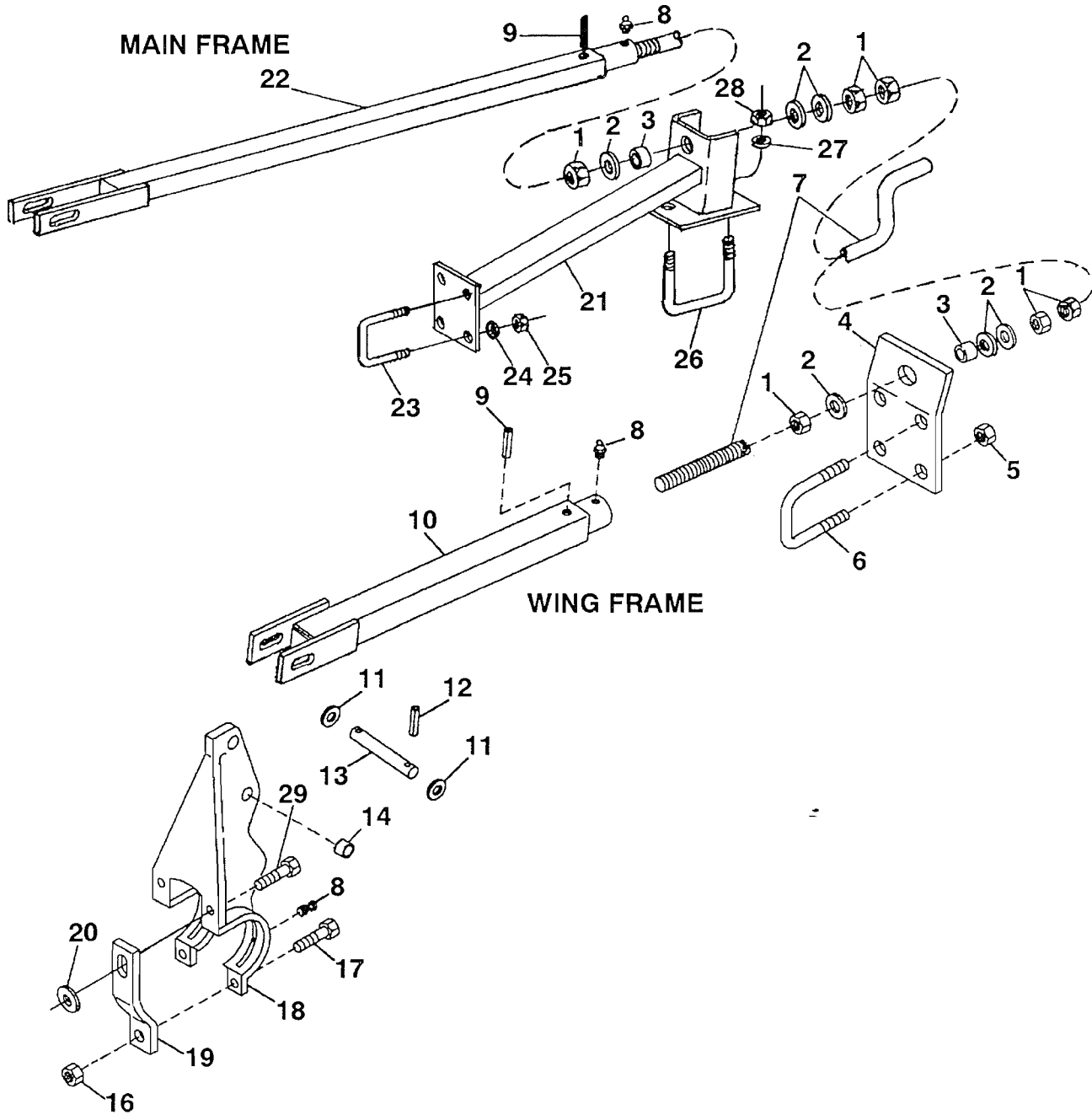

CENTER

FRONT

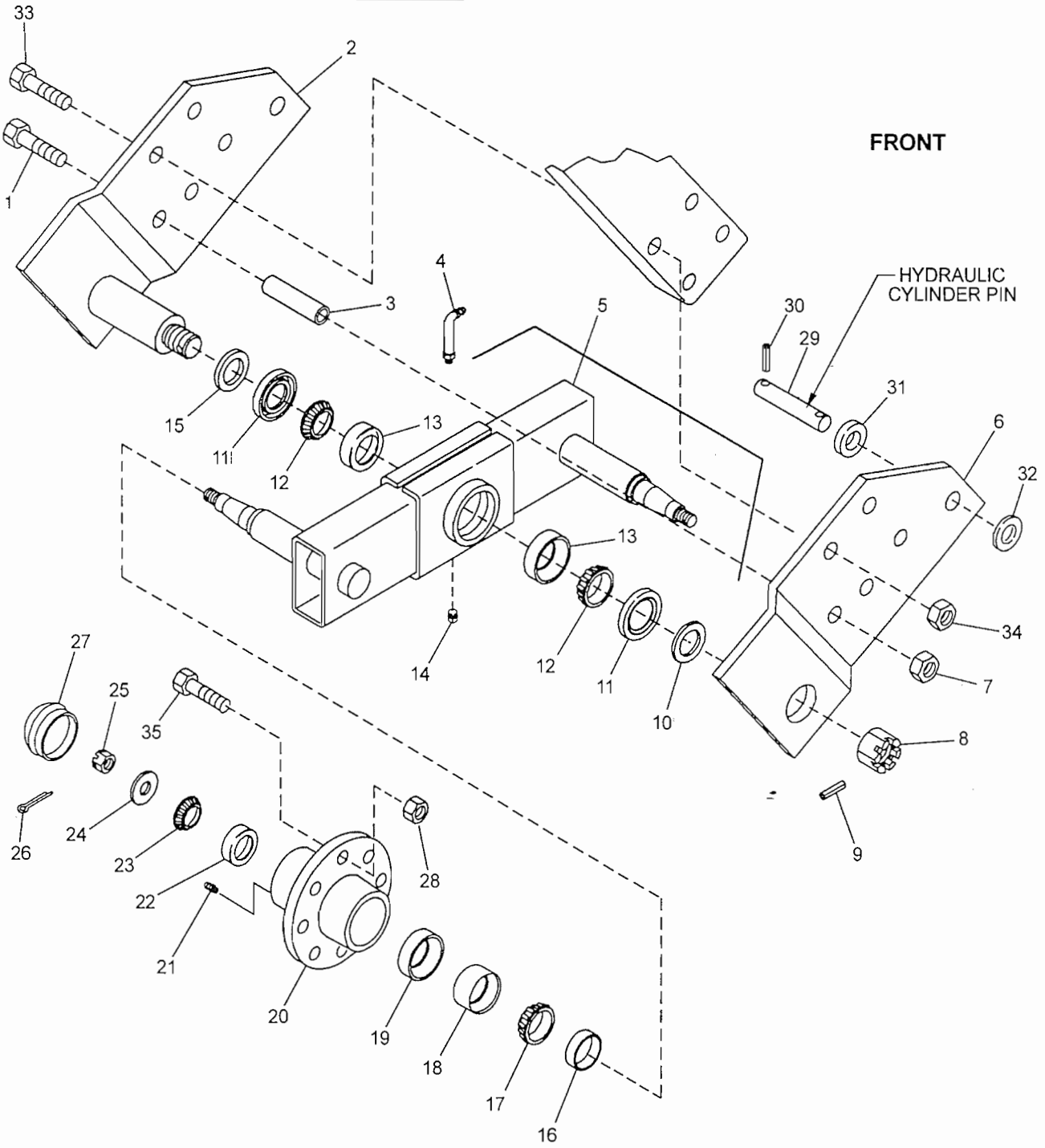

CENTER WALKING BEAM ASSEMBLY

FOR MODELS - ALL

1/98

Item	Part Number	Part Description	Qty.
	5650-57-0A	Left Walking Beam Assembly	1
	5650-58-0A	Right Walking Beam Assembly	1
1	62-213	3/4NC x 6-1/2" GD.5 Cap Screw	1
2	5650-52-0A	Right Side Plate Weldment	1
3	4218-13-1	Spacer Tube	1
4	65-107	1/8NPT x 90° Zerk	1
5	5650-21-0	Repair Walking Beam Weldment	1
6	5650-57-1A	Left Side Plate	1
7	63-112	3/4NC Hex Nut	1
8	5650-57-3	Axle Nut	1
9	60-114	1/4" DIA. x 2" Spiral Expansion Pin	1
10	64-167	Special Washer	1
11	42-131	Seal	2
12	41-114	Cone (#LM-104949)	2
13	41-210	Bearing Cup (#LM-104911)	2
14	75-168	Plug	1
15	5650-57-2	Spacer	1
16	42-109	Seal	1
17	41-114	Cone (#LM-104949)	1
18	53-108	Wear Sleeve	1
19	41-210	Bearing Cup (#LM-104911)	1
20	2490-96-0	Repair Hub Assembly (Includes Items 19, 20, 21, 22, 28, 35)	1
21	65-122	1/4" x 65° Drive Zerk	1
22	41-208	Bearing Cup	1
23	41-112	Cone (#LM-48548)	1
24	64-120	1" SAE Flat Washer (Black)	1
25	63-204	1NF Slotted Hex Nut	1
26	60-702	3/16" DIA. x 1-1/2" Cotter Pin	1
27	52-302	Hub Cap	1
28	63-208	5/8NF Lug Nut	8
29	5648-0-8	Pin (1" DIA. x 6.90")	1
30	60-610	5/16" DIA. x 1-1/2" Roll Pin	2
31	5660-0-23	Spacer	2
32	64-119	1" STD. Flat Washer	2
33	62-213	3/4NC x 6-1/2" GD.5 Cap Screw	4
34	63-112	3/4NC Hex Nut	4
35	62-311	5/8NF x 2-1/4" Wheel Bolt	8
	2135-84-0	Hub Bearing Repair Kit (Includes (1) ea. Items 16, 17, 19, 22, 23)	

MAIN FRAME WING STOP ASSEMBLY

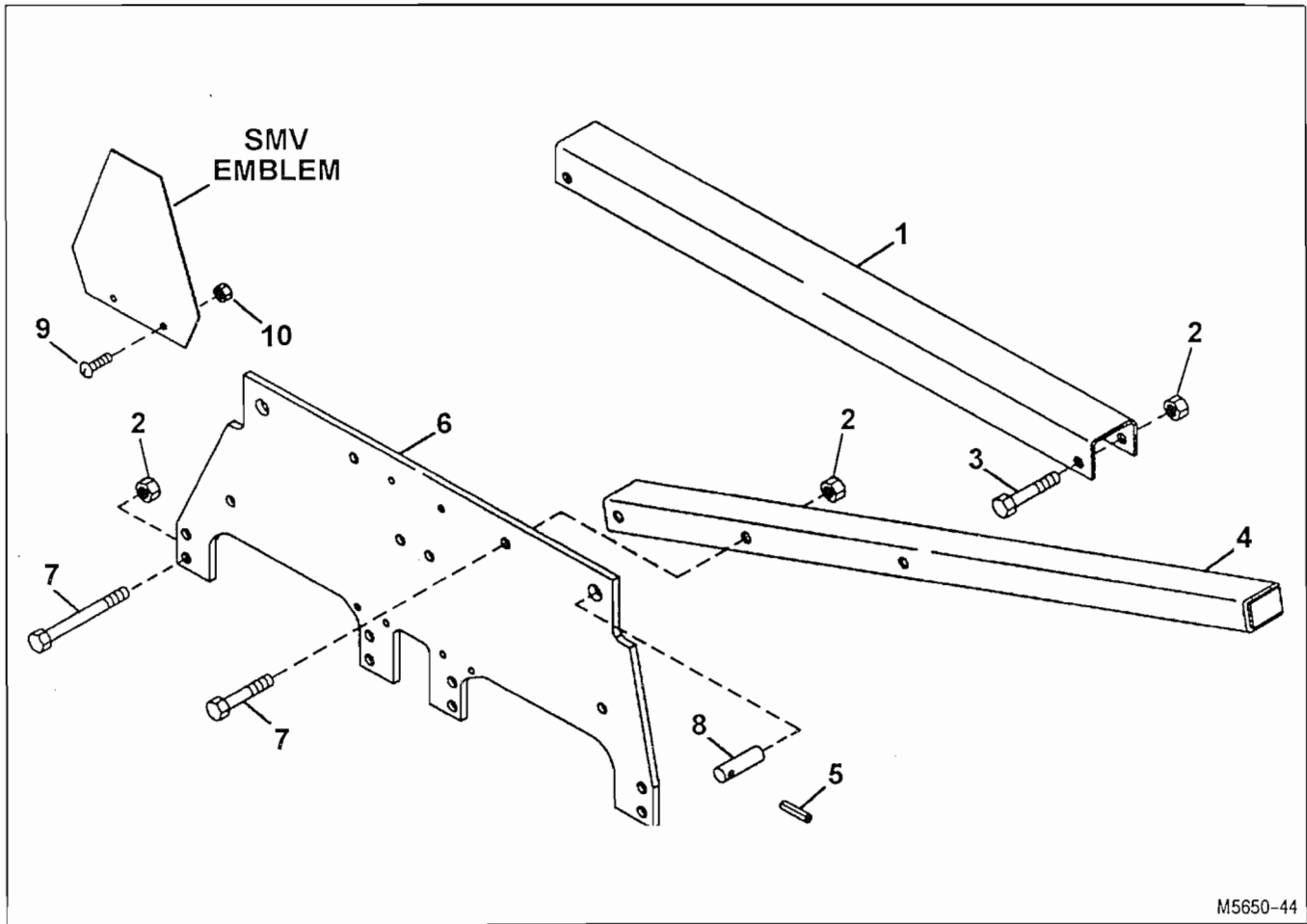

M5650-44

FOR MODELS - ALL

1/93

Item	Part Number	Part Description	Qty.
1	5660-7-0	Channel	2
2	63-109	5/8NC Hex Nut	32
3	62-178	5/8NC x 4" GD.5 Cap Screw	4
4	5660-8-0	Stop Weldment	4
5	60-611	5/16" DIA. x 2" Roll Pin	8
6	5660-37-0	Anchor Plate Weldment	4
7	62-339	5/8NC x 4-1/2" GD.5 Cap Screw	28
8	5648-0-4	Pin (1.25" x 5.35")	4
9	62-350	1/4NC x 1/2" GD.5 Cap Screw	2
10	63-100	1/4NC Hex Nut	2

INNER WING LIFT ASSEMBLY

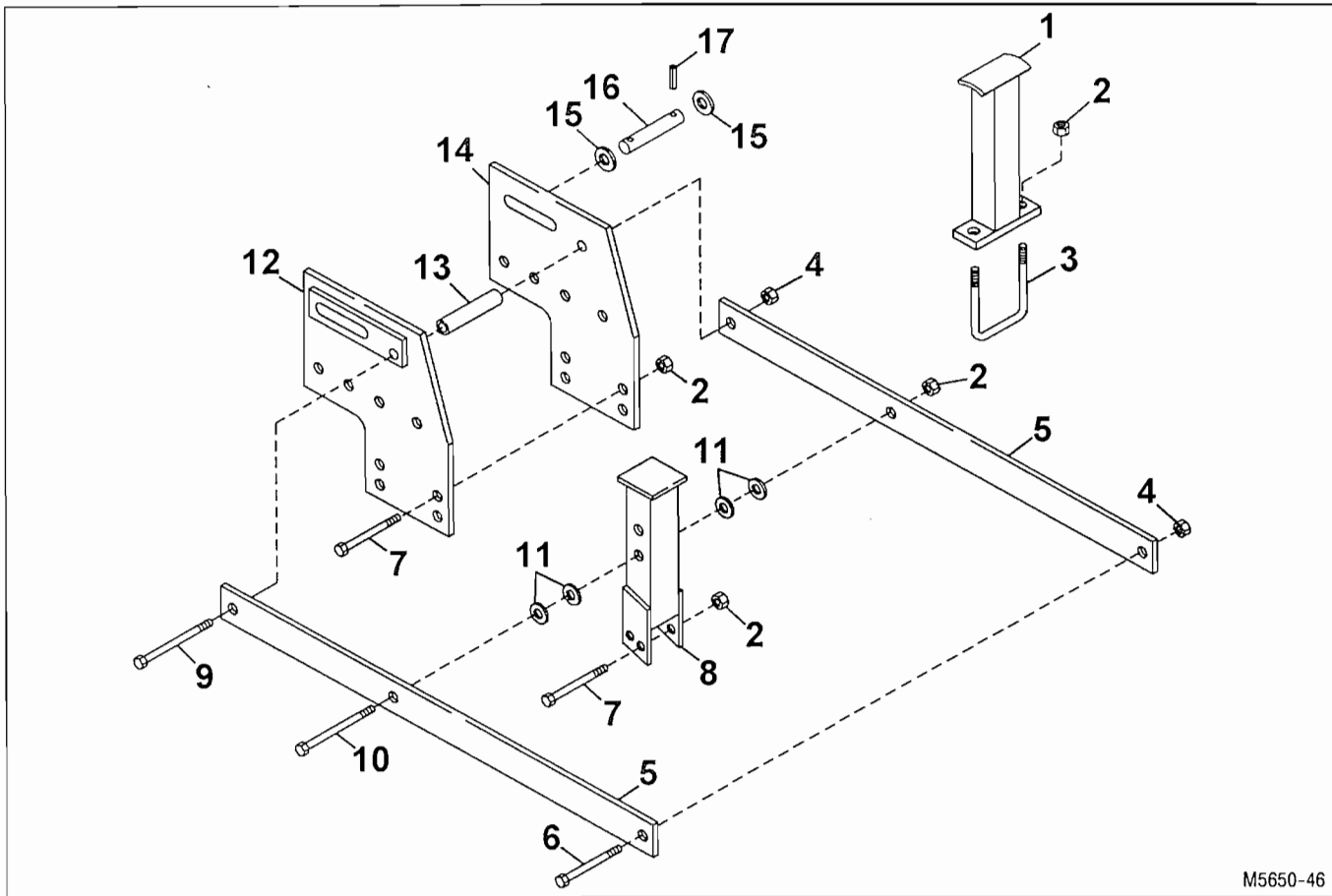

M5650-46

FOR MODELS - ALL

1/98

Item	Part Number	Part Description	Qty.
1	5648-38-0	Stop Weldment	2
2	63-109	5/8NC Hex Nut	26
3	61-235	5/8" DIA. U-Bolt	2
4	63-114	3/4NC Lock Nut	4
5	5648-0-1	Strap (Models 5648 & 5655 ONLY)	4
	5654-0-1	Strap (Model 5654 & 5660 ONLY)	4
6	62-203	3/4NC x 4-1/2" GD.5 Cap Screw	2
7	62-339	5/8NC x 4-1/2" GD.5 Cap Screw	20
8	5648-39-0	Wing Stop Weldment	2
9	62-207	3/4NC x 5-1/2" GD.5 Cap Screw	2
10	62-566	5/8NC x 5-1/2" GD.5 Cap Screw	2
11	64-160	Special Washer 1-3/4" O.D. x 11/16" I.D. x 1/4"	8
12	5648-34-0	Right Lift Plate Weldment	2
13	5654-0-2	Spacer	2
14	5648-35-0	Left Lift Plate Weldment	2
15	64-127	1-1/4" SAE Flat Washer	4
16	5648-0-6	Pin (1-1/4" DIA. x 5-13/16")	2
17	60-611	5/16" DIA. x 2" Roll Pin	4

WING

FRONT

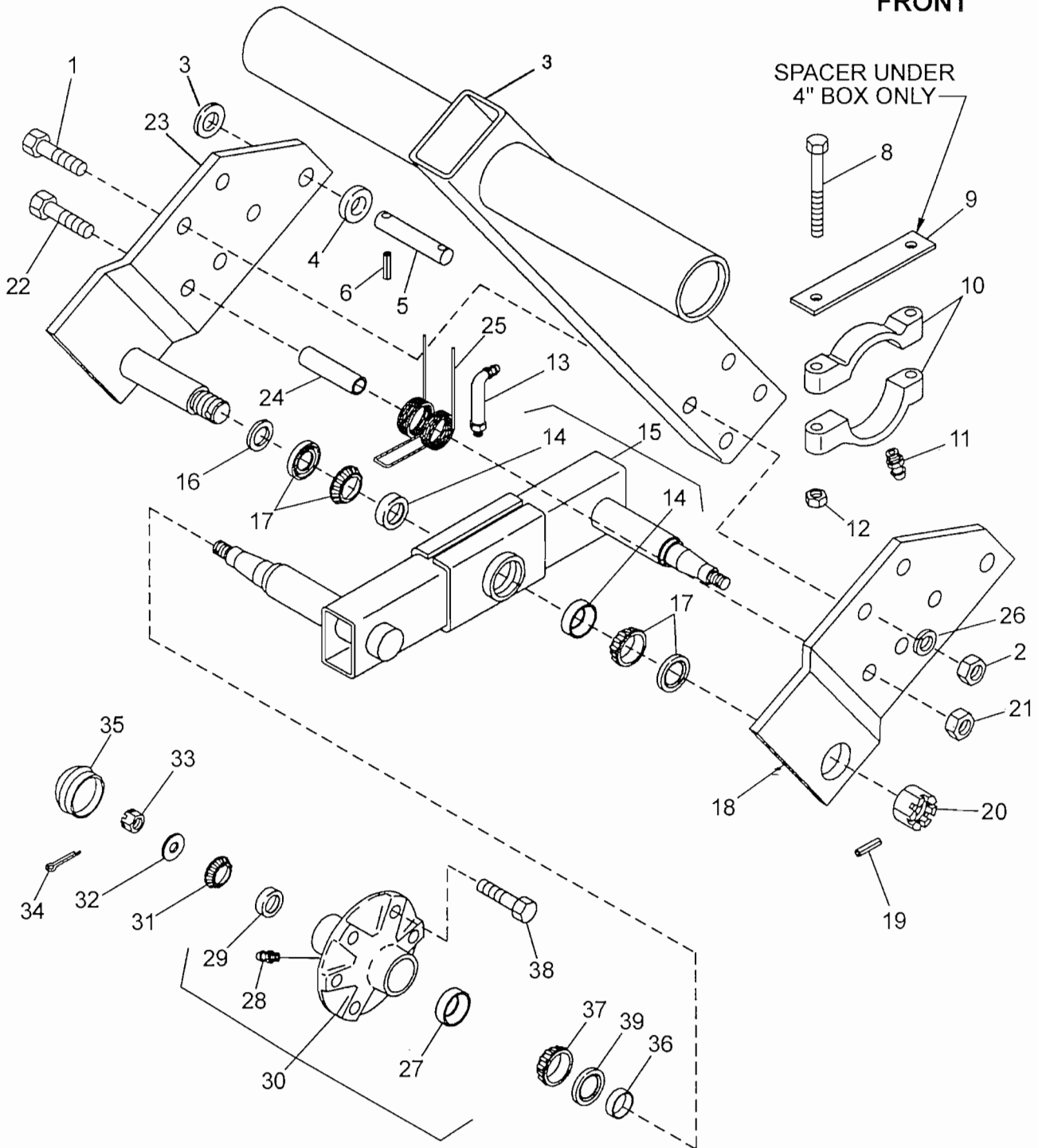

WING ROCKER AND WALKING BEAM ASSEMBLY

FOR MODELS - ALL

1/98

Item	Part Number	Part Description	Qty.
1	62-210	3/4NC x 6" GD.5 Cap Screw	4
2	63-112	3/4NC Hex Nut	4
3	64-119	1" STD. Flat Washer	2
4	5660-0-23	Spacer	2
5	5648-0-5	Pin (1 x 6.65)	1
6	60-610	5/16" DIA. x 1-1/2" Roll Pin	2
7	5660-12-0	Wing Rocker Shaft	1
8	62-581	5/8NC x 11" GD.5 Cap Screw (Inner Wing, Inner Frame Tube)	2
	62-619	5/8NC x 11-1/2" GD.5 Cap Screw (Inner Wing, Outer Frame Tube)	2
	62-581	5/8NC x 11" GD.5 Cap Screw (Outer Wing)	4
9	5660-0-4	Strap	1
10	5660-0-13	Bearing	4
11	65-113	1/4-28UNF Zerk	2
12	63-109	5/8NC Hex Nut	4
	5650-13-0	Left Wing Walking Beam Assembly	1
	5650-14-0	Right Wing Walking Beam Assembly	1
13	65-107	1/8NPT x 90° Zerk	1
14	41-208	Bearing Cup (#LM-48510)	2
15	4218-21-0A	Repair Right Walking Beam Weldment	1
	4218-22-0A	Repair Left Walking Beam Weldment	1
16	4218-13-3	Special Washer	1
17	41-121	Cone / Seal Assembly (#LM-48500LA)	2
18	5650-13-1	Left Side Plate	1
19	60-114	1/4" DIA. x 2" Spiral Expansion Pin	1
20	4218-13-2	Axle Nut	1
21	63-112	3/4NC Hex Nut	1
22	62-210	3/4NC x 6" GD.5 Cap Screw	1
23	5650-19-0	Right Side Plate Weldment	1
24	4218-13-1	Spacer Tube	1
25	76-131	Torsion Spring	1
26	64-112	3/4" STD. Lock Washer	1
27	41-209	Bearing Cup (#25520)	1
28	65-122	1/4 x 65° Zerk	1
29	41-208	Bearing Cup (#LM-48510)	1
30	1918-14-0A	Repair Hub (Includes Items 27, 29,30,38)	1
31	41-112	Cone (#LM-48548)	1
32	64-120	1" SAE Flat Washer	1
33	63-204	1-14NF Slotted Hex Nut	1
34	60-702	3/16" DIA. x 1-1/2" Cotter Pin	1
35	52-302	Hub Cap	1
36	53-105	Wear Sleeve	1
37	41-113	Cone (#25580)	1
38	62-295	9/16NF x 1-1/8" GD.5 Wheel Bolt	6
39	42-108	Seal	1
	1918-84-0	Hub Bearing Repair Kit (Includes (1) ea. Items 27, 29, 31, 37 & 39)	

OUTER WING EXTENSION

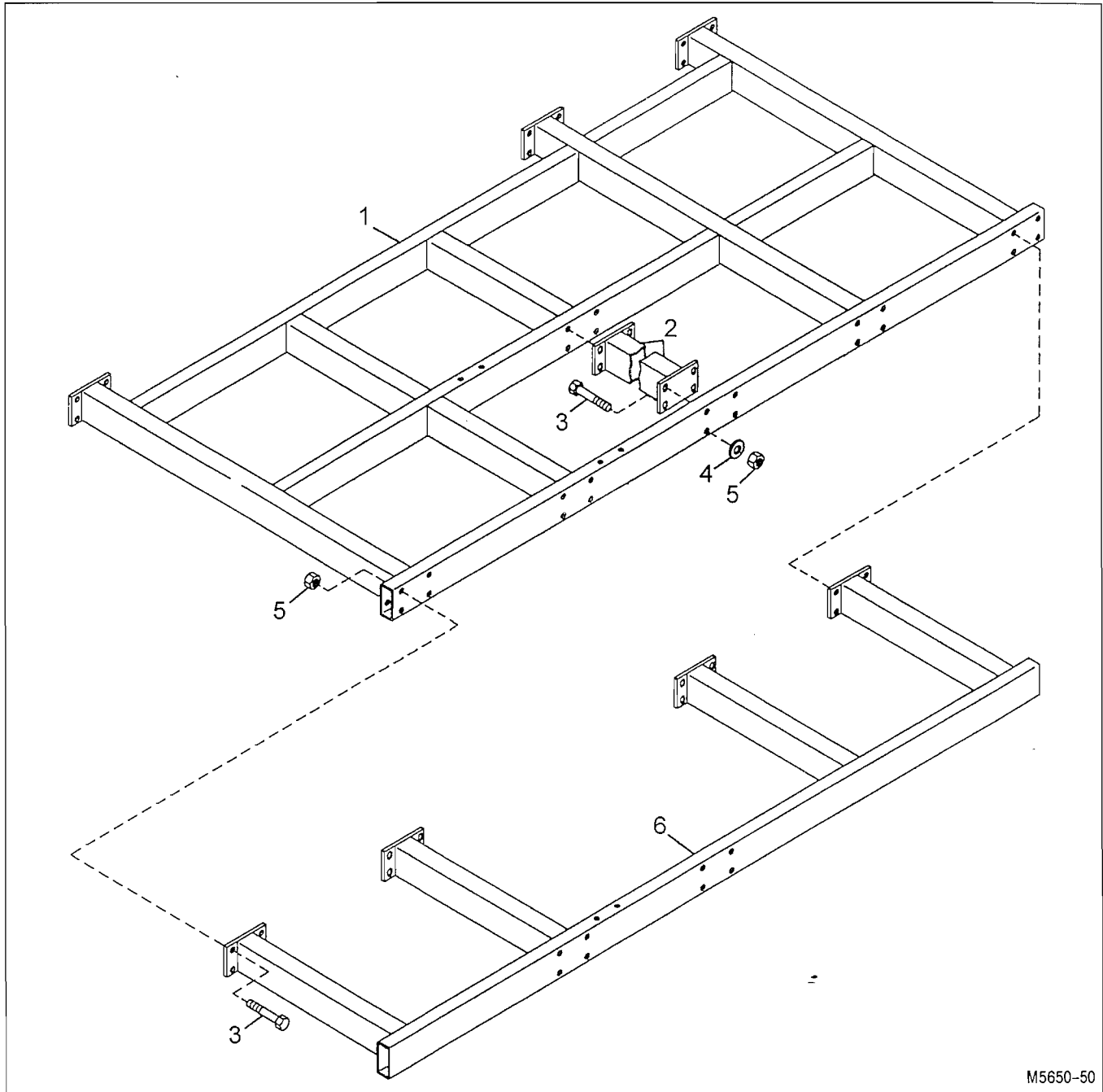

M5650-50

FOR MODELS - ALL

6/96

Item	Part Number	Part Description	Qty.
1	5648-22-0	Outer Wing Frame Weldment	2
	■ 5655-22-0	Outer Wing Frame Weldment	2
2	★ 5660-28-0	Tube Weldment	2
3	★ 62-176	5/8NC x 3-1/2" GD.5 Cap Screw	48
4	★ 64-110	5/8" STD. Flat Washer	32
5	★ 63-109	5/8NC Hex Nut	48
6	★ 5660-22-0	Wing Extension Weldment	2
★ On Model 5660 ONLY			
■ On Model 5655 ONLY			

180° FOLD HINGE ASSEMBLY

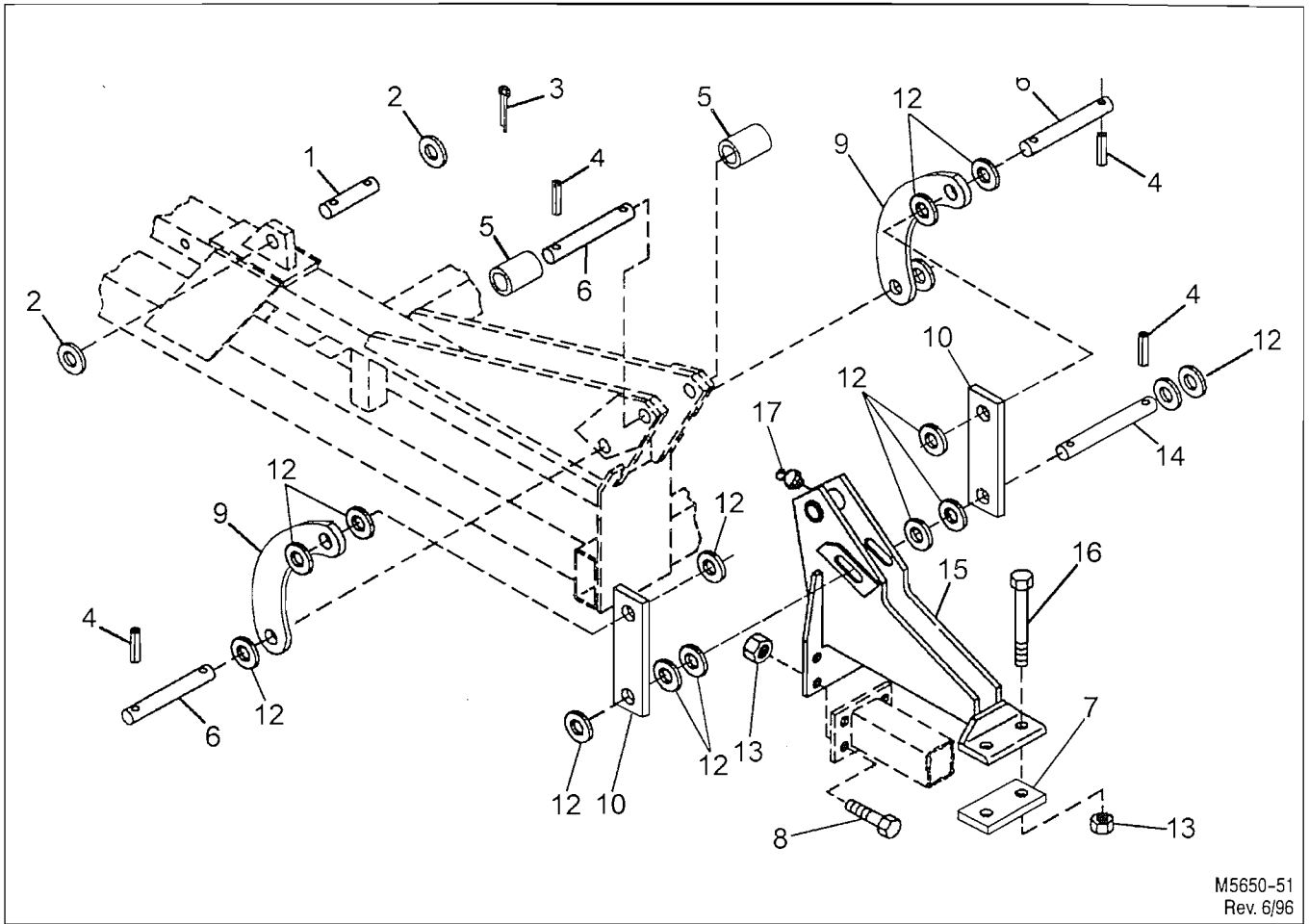

M5650-51
Rev. 6/96

FOR MODELS – ALL

6/96

Item	Part Number	Part Description	Qty.
1	5660-0-25	Pin (1.25 x 4.48")	4
2	64-138	Special Washer (2 x 1-5/16 x 1/8)	8
3	60-712	5/16" DIA. x 2-1/2" Cotter Pin	8
4	60-615	3/8" DIA. x 2" Roll Pin	16
5	5660-0-27	Bushing	8
6	5660-0-8	Pin (1.25 x 8.00)	12
7	5660-0-17	Strap (.62 x 2 x 5.69)	4
8	62-169	5/8NC x 2" GD.5 Cap Screw	16
9	5660-0-11	Curved Link	8
10	5660-0-6	Hinge Strap	8
11			
12	64-127	1-1/4" SAE Flat Washer	69
13	63-109	5/8NC Hex Nut	24
14	5648-0-7	Pin (1.25 x 7.00)	4
15	5660-42-0	Hinge Weldment	4
16	62-393	5/8NC x 6" GD.5 Cap Screw	8
17	65-113	1/4-28UNF Zerk	4

FRONT HINGE ASSEMBLY

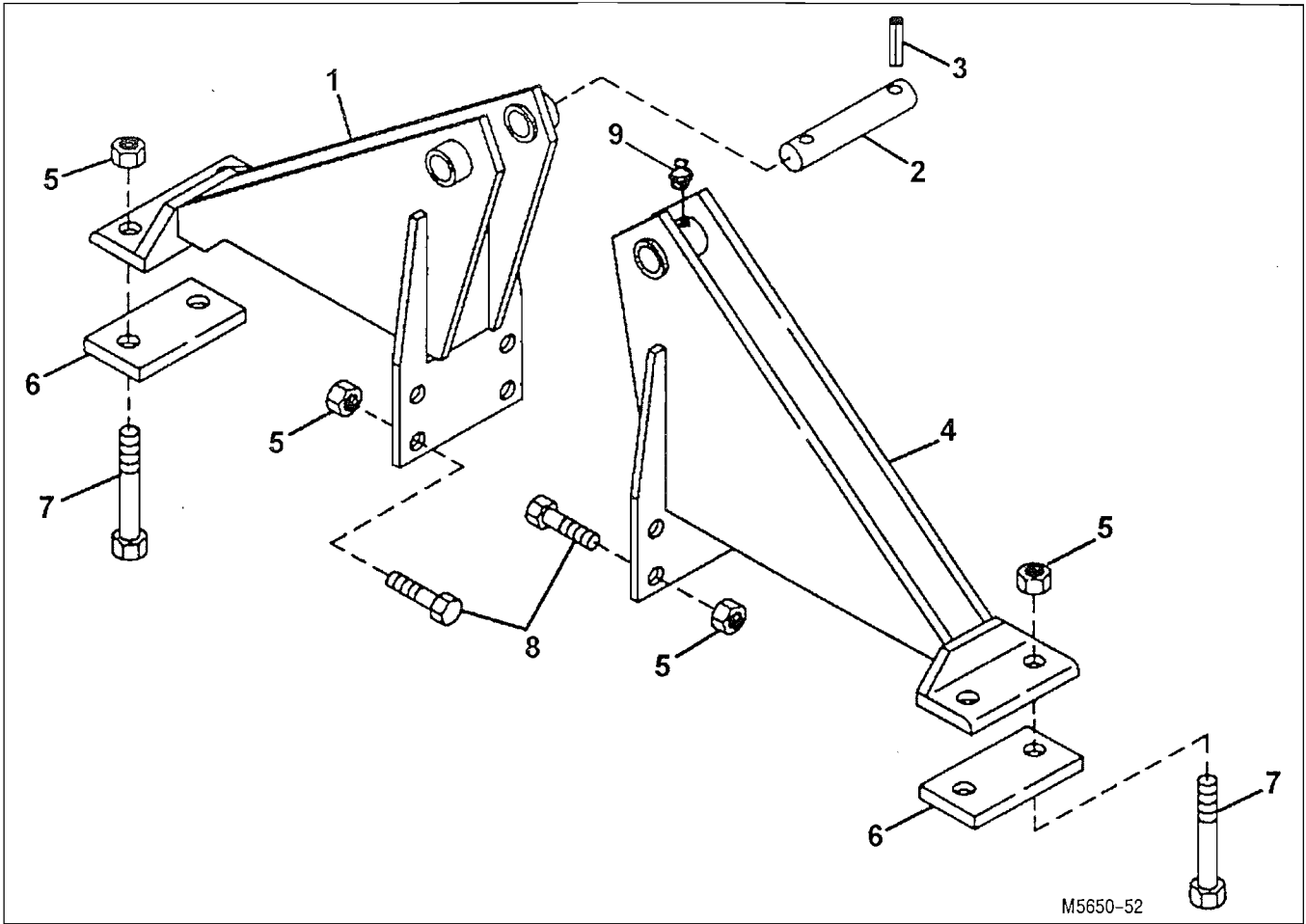

FOR MODELS - ALL

1/93

Item	Part Number	Part Description	Qty.
1	5660-41-0	Inner Hinge Weldment	2
2	5660-0-7	Hinge Pin (1.25 x 6.28)	2
3	60-615	3/8" DIA. x 2" Roll Pin	4
4	5660-43-0	Outer Hinge Weldment	2
5	63-109	5/8NC Hex Nut	24
6	5660-0-17	Strap (.62 x 2 x 5.69)	4
7	62-393	5/8NC x 6" GD.5 Cap screw	8
8	62-169	5/8NC x 2" GD.5 Cap Screw	16
9	65-114	1/4-28UNF Zerk	2

STUB SHANK EXTENSIONS AND FRONT SHANK EXTENSION

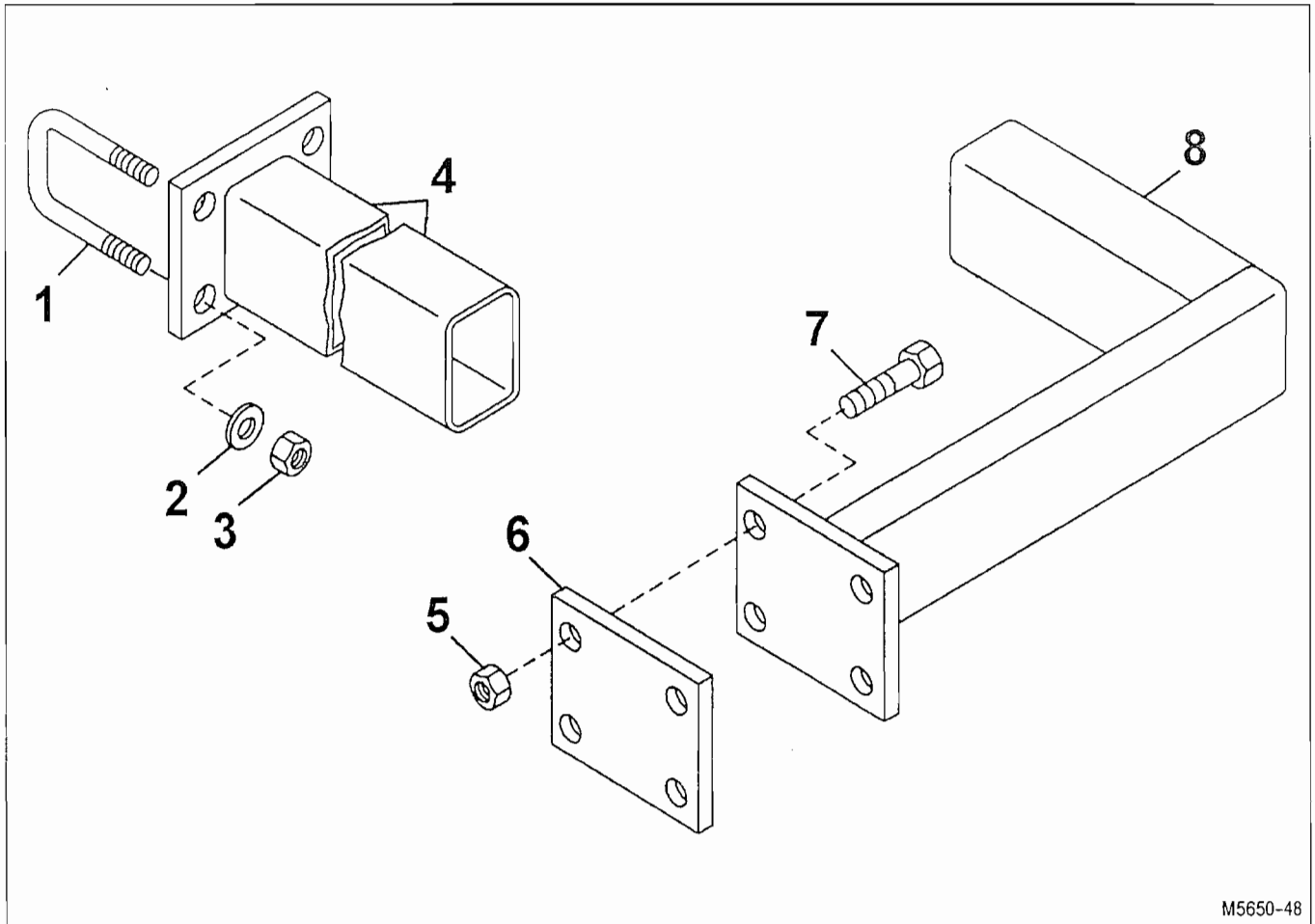

M5650-48

FOR MODELS - ALL

6/96

Item	Part Number	Part Description	Qty.
1	★ 61-198	5/8" DIA. U-Bolt (5 x 2 Box)	2
	61-126	5/8" DIA. U-Bolt (4 x 3 Box)	2
2	★ 64-109	5/8" STD. Lock Washer	4
3	63-109	5/8NC Hex Nut	4
4	4236-26-0	12" Stub Weldment (For 6" Spacing Unit) - For 4" Frame	1
	5660-16-0	6" Stub Weldment (For 9" Spacing Unit) - For 4" Frame	1
	★ 5660-25-0	6" Stub Weldment - For 5" Frame	1
	★ 5660-27-0	15" Stub Weldment - For 5" Frame	1
5	63-109	5/8NC Hex Nut	4
6	5660-0-24	Bolt Plate	1
7	62-439	5/8NC x 5" GD.5 Cap Screw	4
8	5660-23-0	Extension Tube Weldment, Front	1
★ For Accessory 2 & 4 Shank Extensions ONLY			

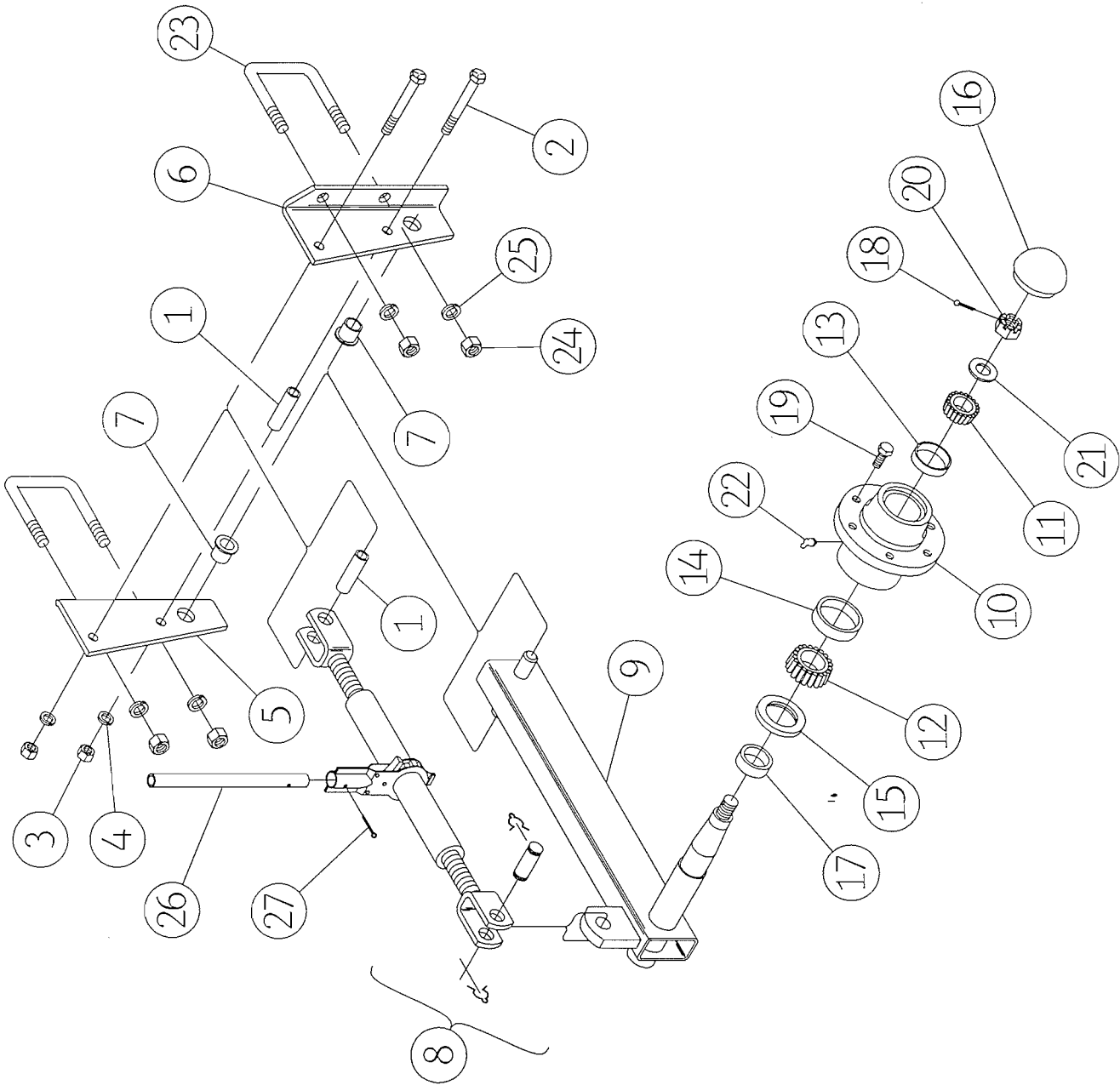

HYDRAULIC HOSE WITH PLASTIC GRIP ASSEMBLIES

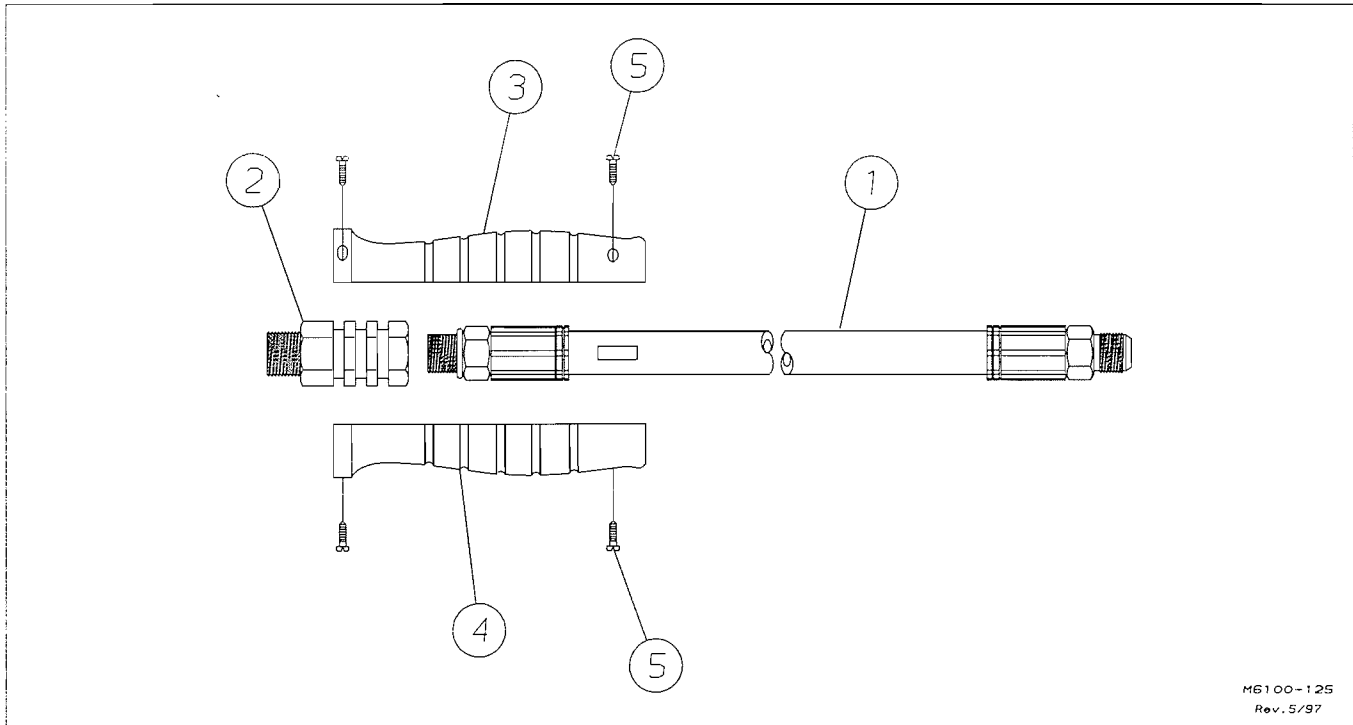

H6100-125
Rev. 5/97

FOR MODELS - ALL

8/97

Item	Part Number	Part Description	Qty.
	4990-75-0	1/2" x 92" 100R2 Hose with Red/Red Grip Assembly	1
1	24-330R	1/2"DIA. x 92" JIC/ORB 100R2 Hose	1
2	25-2295	3/4"ORB to 1/2NPT Hydraulic Fitting	1
3	25-2289	Hose Grip Half - Red	1
4	25-2289	Hose Grip Half - Red	1
5	62-656	Screw	4
	4990-76-0	1/2" x 92" 100R2 Hose with Yellow/Yellow Grip Assembly	1
1	24-330R	1/2"DIA. x 92" JIC/ORB 100R2 Hose	1
2	25-2295	3/4"ORB to 1/2NPT Hydraulic Fitting	1
3	25-2290	Hose Grip Half - Yellow	1
4	25-2290	Hose Grip Half - Yellow	1
5	62-656	Screw	4
	4990-77-0	3/8" x 92" 100R2 Hose with Red/Black Grip Assembly	1
1	24-2105R	3/8"DIA. x 92" JIC/ORB 100R2 Hose	1
2	25-2295	3/4"ORB to 1/2NPT Hydraulic Fitting	1
3	25-2289	Hose Grip Half - Red	1
4	25-2291	Hose Grip Half - Black	1
5	62-656	Screw	4
	4990-78-0	3/8" x 92" 100R2 Hose with Yellow/Black Grip Assembly	1
1	24-2105R	3/8"DIA. x 92" JIC/ORB 100R2 Hose	1
2	25-2295	3/4"ORB to 1/2NPT Hydraulic Fitting	1
3	25-2290	Hose Grip Half - Yellow	1
4	25-2291	Hose Grip Half - Black	1
5	62-656	Screw	4

WHEELS & TIRES, SAFETY CHAIN, JACK & REAR JACK

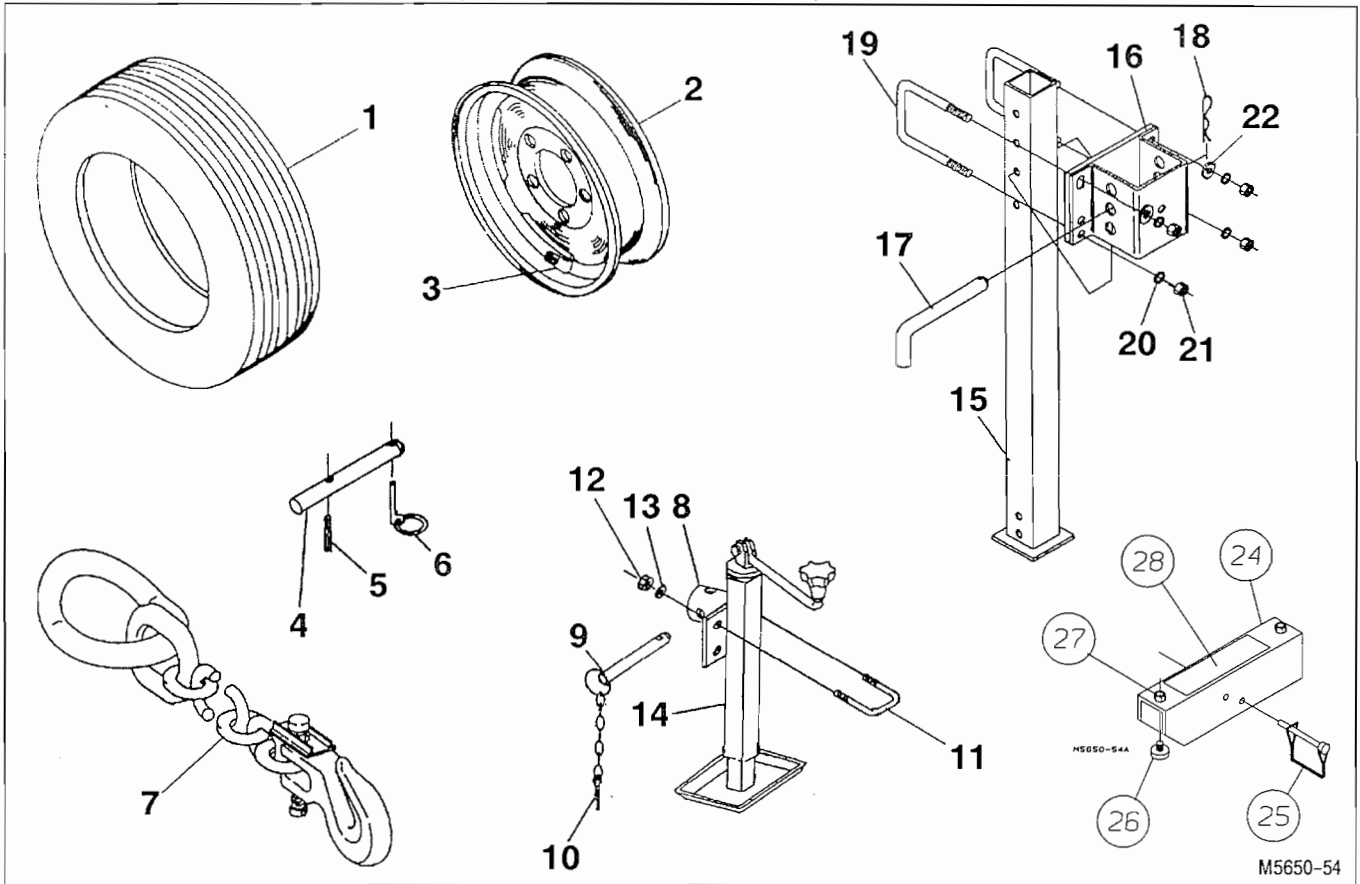

M5650-54

FOR MODELS - ALL

8/97

Item	Part Number	Part Description	Qty.	Item	Part Number	Part Description	Qty.
	1000-95588-0	Wheel Assembly	1	5648-29-0	Rear Stand Assembly	2	
1	51-102	Tire 9.5L x 15, 8-Ply	1	15	5648-27-0	Stand Weldment	1
2	52-102	Wheel 15" x 8"	1	16	5648-28-0	Stand Bracket Weldment	1
3	51-107	Valve Stem	1	17	5648-29-1	Stand Pin	1
				18	60-716	#3 Hair Pin Cotter	1
	1000-12640-01	Wheel Assembly	1	19	61-174	3/4" DIA. U-Bolt	4
1	51-122	Tire, 12.5L x 16, 14-Ply	1	20	64-112	3/4" STD. Lock Washer	8
2	52-112	Wheel, 16" x 10" 8-Bolt	1	21	63-112	3/4NC Hex Nut	8
3	51-107	Valve Stem	1	22	64-114	3/4" SAE Flat Washer	4
4	4025-0-3	Hitch Pin	1	23	5800-17-0	Cylinder Lock Assembly	2
5	60-617	3/8" DIA. x 2-1/2" Roll Pin	1	24	6124-17-1	Road Lock Channel	1
6	60-102	Klik Pin	1	25	60-103	P.T.O. Lock Pin	1
7	72-352	20,000# Ag Safety Chain	1	26	44-107	Rubber Threaded Bumper	2
				27	63-102	3/8NC Hex Nut	2
	5660-65-0	Jack Assembly	1	28	74-387	Decal, Cylinder Lock	1
8	5660-55-0	Mounting Bracket Weldment	1				
9	60-106	FAS-Pin with Chain	1				
10	60-702	3/16"DIA.x 1-1/2" Cotter Pin	1				
11	61-172	1/2" DIA. U-Bolt	2				
12	63-106	1/2NC Hex Nut	4				
13	64-107	1/2" STD. Lock Washer	4				
14	73-111	Jack Assembly	1				

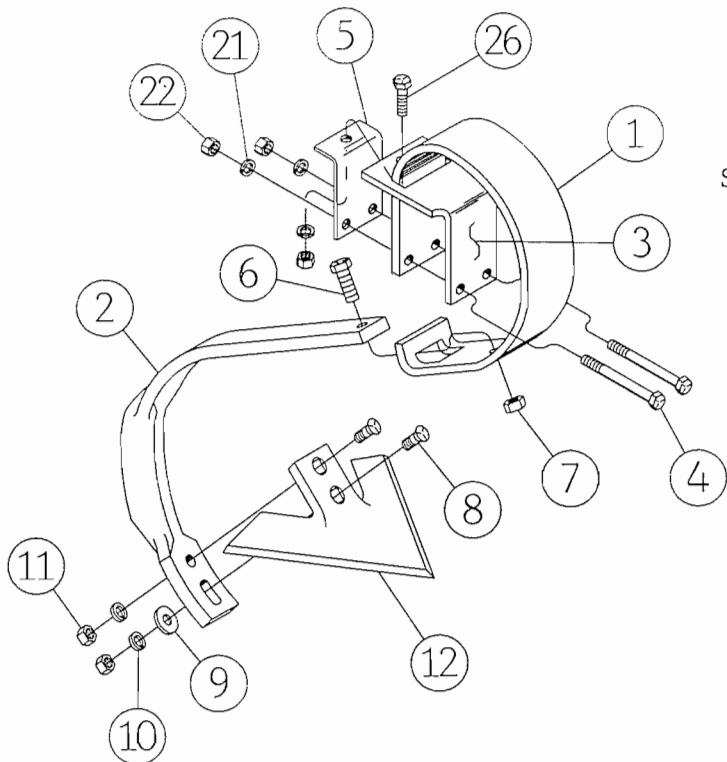

STANDARD MOUNT

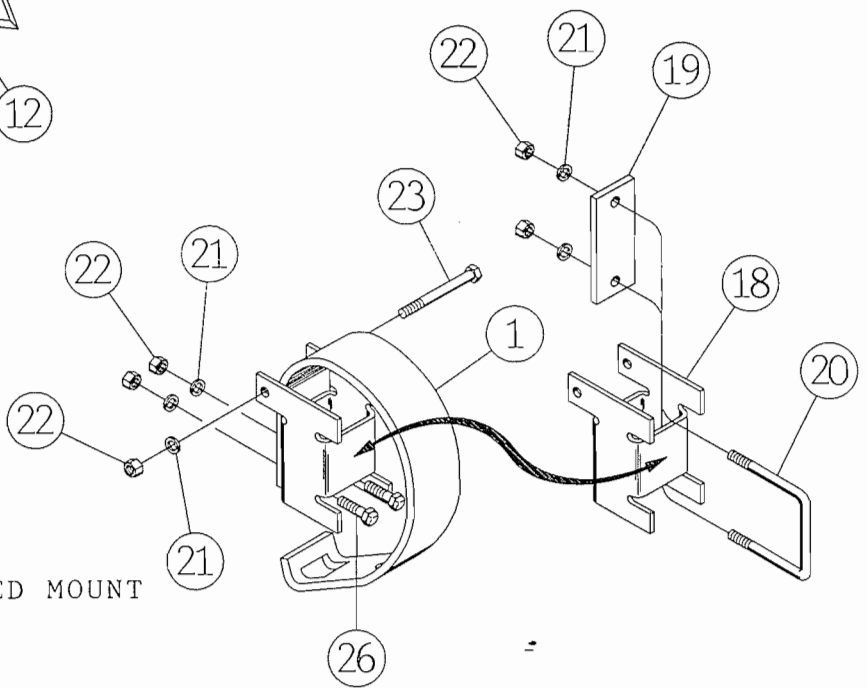

EXTENDED MOUNT

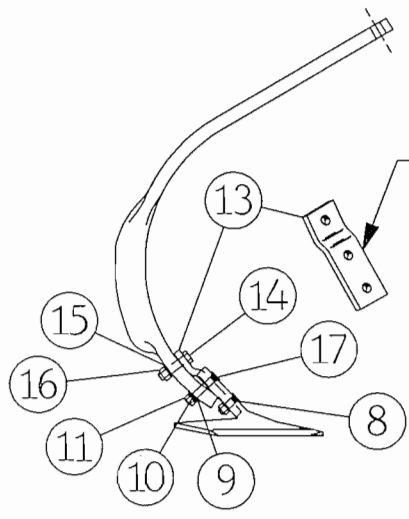

USE EXTENSION SHANK AT SHANK LOCATIONS IN TRACTOR TRACK IF NEEDED.

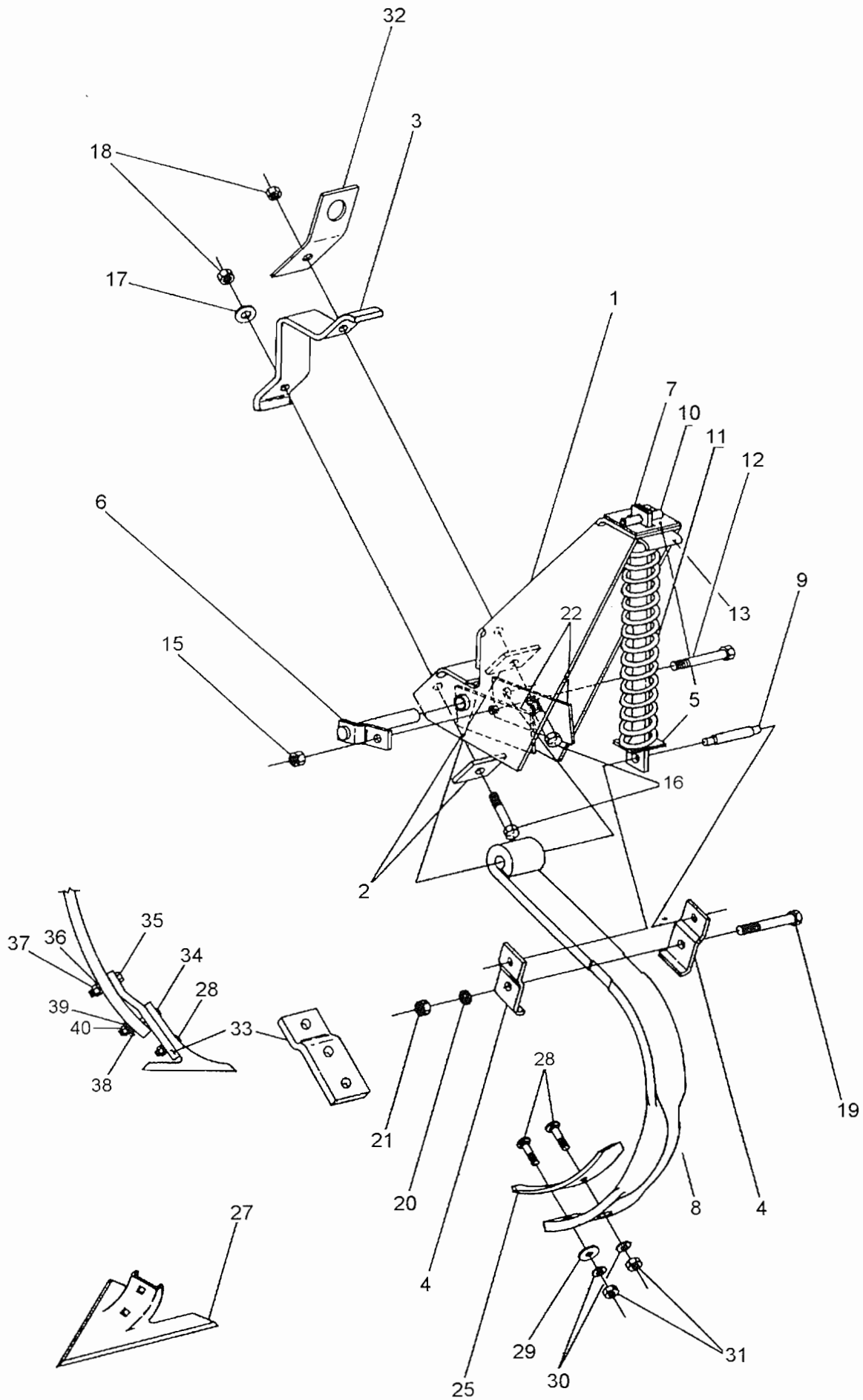

Rev.1/98
M5650-56

SPRING SHANK ASSEMBLY

FOR MODELS – ALL

8/97

Item	Part Number	Part Description	Qty.
	3127-25-0B	Spring Shank Assembly	1
1	3127-24-0	Mounting Channel (For Repairs Only)	1
2	★ 3127-25-3	Doubler	2
3	★ 3127-25-5	Mounting Strap	1
4	3127-25-8	Shank Clamp	2
5	3127-39-2	Slotted Washer	2
6	3127-37-0A	Pin Assembly	1
7	3127-39-1A	Guide Bar	1
8	31-157	Edge-On Shank	1
9	60-105	Pivot Pin	1
10	60-624	1/2" DIA. x 2" Roll Pin	1
11	76-134	Spring	1
12	62-462	1/2NC x 3-1/4" GD5 Cap Screw	1
13	3127-24-2A	Slot Doubler	1
14			
15	63-107	1/2NC Self Locking Nut	1
16	★ 62-550	1/2NC x 2" GD.8 Cap Screw	2
17	★ 64-108	1/2" STD. Flat Washer	1
18	★ 63-107	1/2NC Self Locking Nut	2
19	62-148	1/2NC x 2-3/4" GD5 Cap Screw	1
20	64-107	1/2" STD. Lock Washer	1
21	63-106	1/2NC Hex Nut	1
22	3127-25-7	Shank Guide	2
23			
24			
25	★ 33-100	Point	1
26			
27	★ 33-189	9" Sweep 47° Stem Angle – 1/4" Thick	1
	33-190	10" Sweep 47° Stem Angle – 1/4" Thick	1
28	★ 62-317	7/16NC x 1-1/2" GD.5 #3 Plow Bolt	3
29	★ 64-106	7/16" STD. Flat Washer	1
30	★ 64-105	7/16" STD. Lock Washer	3
31	★ 63-104	7/16NC Hex Nut	3
32	★ 4122-0-14	Winch Bracket (Shown in storage position)	1
	4100-10-0	Extension Shank and Bolt Assembly	1
33	★ 4100-0-9	Extension Shank	1
34	★ 62-132	7/16NC x 2-1/4" GD.5 #3 Plow Bolt	1
35	★ 62-407	7/16NC x 1-1/2" GD.5 Cap screw	1
36	★ 64-105	7/16" STD. Lock Washer	1
37	★ 63-104	7/16NC Hex Nut	1
38	★ 64-104	7/16" STD. Flat Washer	1
39	★ 64-105	7/16" STD. Lock Washer	1
40	★ 63-104	7/16NC Hex Nut	1
★ Not part of 3127-25-0B Spring Shank Assembly			

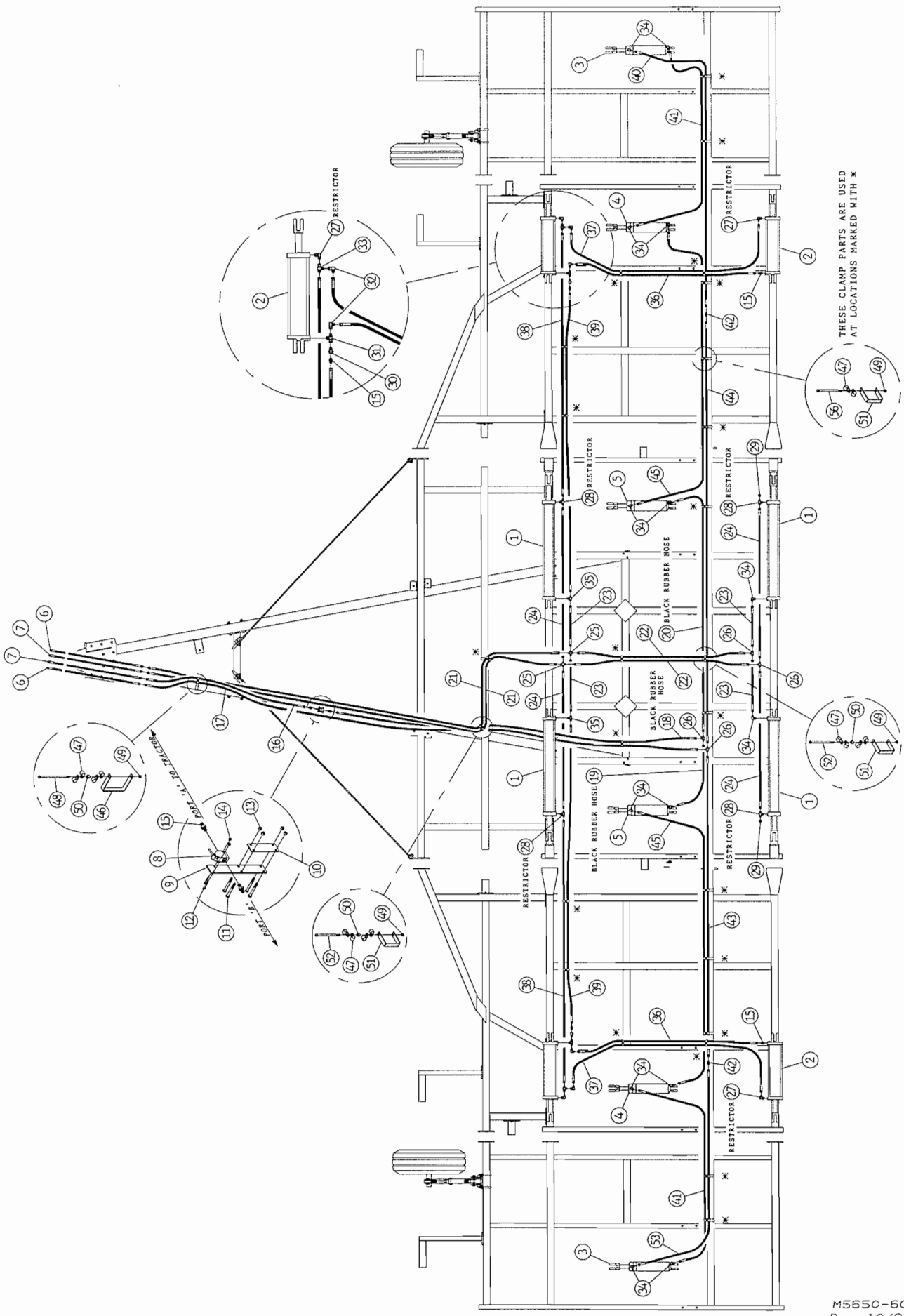

M5650-60
Rev. 10/97

HYDRAULIC HOSE GROUP

FOR MODELS – ALL

8/97

Item	Part Number	Part Description	Qty.	Item	Part Number	Part Description	Qty.
1	21-168	4 x 40 Side Port Prince Cylinder	4	41	★■ 24-2109R	3/8" x 114" JIC Hose	2
2	21-177	5 x 16 Prince Cylinder	4		□ 24-271R	3/8" x 132" JIC Hose	2
3	22-127	3-1/2 x 12 Eaton Cylinder	2		▲ 24-228R	3/8" x 149" JIC Hose	2
4	22-128	3-3/4 x 12 Eaton Cylinder	2	42	25-304	37 Flare Male Adapter	2
5	22-129	4 x 12 Eaton Cylinder	2	43	★ 24-222R	3/8" x 125" JIC Hose	1
6	● 4990-75-0	1/2 x 92Hose w/ Red Grip	1		■□ 24-242R	3/8" x 161" JIC Hose	1
7	● 4990-76-0	1/2 x 92 Hose w/ Yellow Grip	1		▲ 24-298R	3/8" x 151" JIC Hose	1
	5660-39-0	Lock Valve & Mounting Asm.	1	44	★ 24-2101R	3/8" x 187" JIC Hose	1
8	25-2272	Lock Valve	1		■□ 24-226R	3/8" x 143" JIC Hose	2
9	5660-0-2	Valve Bracket	1		□ 24-242R	3/8" x 161" JIC Hose	2
10	5660-0-3	Bolt Plate	1		■▲ 24-232R	3/8" x 178" JIC Hose	2
11	62-458	1/2NC x 5" GD5 Cap Screw	4	46	5654-0-3	Hose Mount Clevis (6 x 4 Box)	1
12	62-394	5/16NC x 2-1/2"GD.5 Bolt	2	47	25-127	3/4" I.D. Hose Clamp	58
13	63-107	1/2NC Lock Nut	4	48	62-130	3/8NC x 8-1/2" Cap Screw	1
14	63-135	5/16NC Hex Nut	2	49	63-103	3/8NC Lock Nut	26
15	25-300	O-Ring 37° Flare Male Adapter	6	50	63-106	1/2NC Hex Nut (Spacer)	3
16	24-314R	1/2 x 90" JIC Hose	1	51	5654-0-4	Hose Mount Clevis (4 x 3 Box)	25
17	24-311R	1/2 x 242" JIC Hose	1	52	62-426	3/8NC x 6-1/2" GD.5 Cap Screw	3
18	24-372R	1/2 x 150" 100R2 Rubber Hose	1	53	★■ □ 24-265R	3/8" x 135" JIC Hose	1
19	24-393R	1/2 x 36" 100R2 Rubber Hose	1		▲ 24-274R	3/8" x 170" JIC Hose	1
20	24-397R	1/2 x 132" 100R2 Rubber Hose	1	54	● 4990-77-0	3/8" x 92" Hose w/ Red/Black Grip	1
21	24-361R	1/2 x 200" JIC Hose	2	55	● 4990-78-0	3/8 x 92"Hose w/Yellow/Black Grip	1
22	24-306R	1/2 x 81" JIC Hose	2		25-126	27-1/2" Panduit Stay Strap (use as needed)	4
23	24-394R	1/2 x 27" JIC Hose	4	56	62-126	3/8NC x 5-1/2"GD5 Cap Screw	22
24	24-304R	1/2 x 70" JIC Hose	4				
25	25-361	37° Flare 3/4 Male Cross Fitting	2				
26	25-303	37° Flare 3/4 Male Tee Fitting	4				
27	4956-76-0	25-305 Restrictor Elbow w/ Tag	4				
28	3775-75-0	25-306 Restrictor Tee w/ Tag	4				
29	25-364	3/4 Cap Nut	2				
30	25-140	Line Check Valve	2				
31	25-315	O-Ring 37° Flare M / F Tee	2				
32	25-310	37° Flare M / F 90° Elbow	4				
33	25-307	37° Flare M / F Tee	2				
34	25-301	O-Ring 37° Flare 90° Elbow	14				
35	25-309	O-Ring 37° Flare Tee	2				
36	24-236R	3/8 " x 98" JIC Hose	2				
37	24-291R	3/8" x 120" JIC Hose	2				
38	★ 24-223R	3/8" x 128" JIC Hose	2				
	□ 24-276R	3/8" x 146" JIC Hose	2				
	■▲ 24-2100R	3/8" x 164" JIC Hose	2				
39	★ 24-298R	3/8" x 151" JIC Hose	2				
	□ 24-2122R	3/8" x 170" JIC Hose	2				
	■▲ 24-2101R	3/8" x 187" JIC Hose	2				
40	★■ □ 24-289R	3/8" x 166" JIC Hose	1				
	▲ 24-259R	3/8" x 202" JIC Hose	1				

★ Model 5648

■ Model 5654

□ Model 5655

▲ Model 5660

● See page P22 for parts listing

PRINCE HYDRAULIC CYLINDER ASSEMBLY

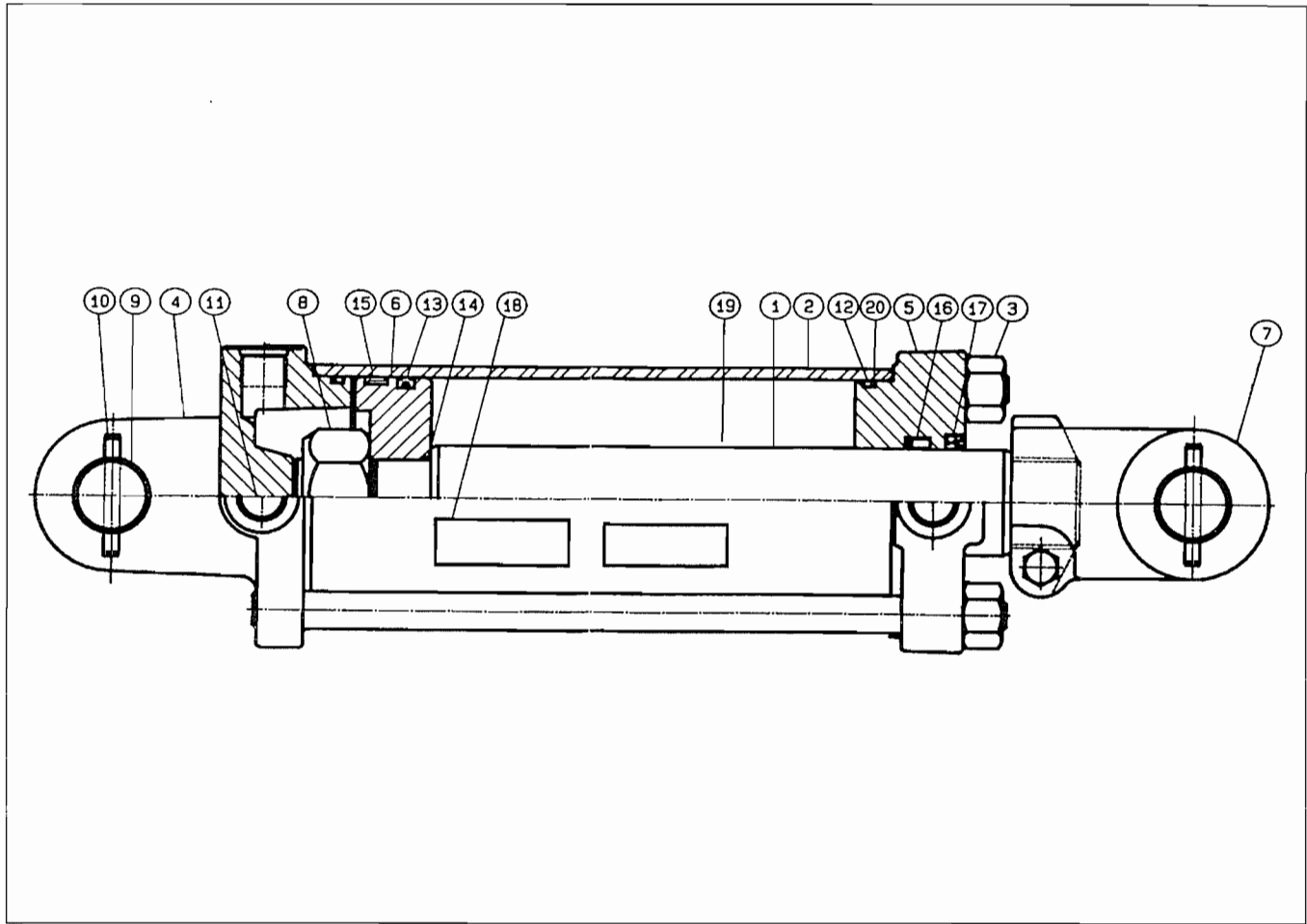

21-168 4" X 40" HYDRAULIC CYLINDER ASSEMBLY 7/97
 Retracted - 50-3/4" Extended - 90-3/4" Stroke - 40" Rod Diameter - 1-3/4"

Item	Part Number	Part Description	Qty.
1	21-877	Piston Rod	1
2	21-831	Port Plug	3
3	21-371	Tube	1
4	21-882	Butt	1
5	21-878	Gland	1
6	★	Crown Seal	1
7	21-286	Lock Nut	1
8	21-507	Clevis Assembly	1
9	21-939	Tie Rod	4
10	★	O-Ring	2
11	★	Bearing Ring	1
12	★	O-Ring	1
13	21-879	Piston	1
14	★	U-Cup	1
15	★	Wiper	1
16	21-872	Clevis Pin	2
17	21-860	Roll Pin	4
18	74-113	Cylinder WARNING Decal	1
19	★	Back-Up Washer	2
	21-857	Seal Kit (★ Items Included in Kit)	

PRINCE HYDRAULIC CYLINDER ASSEMBLY

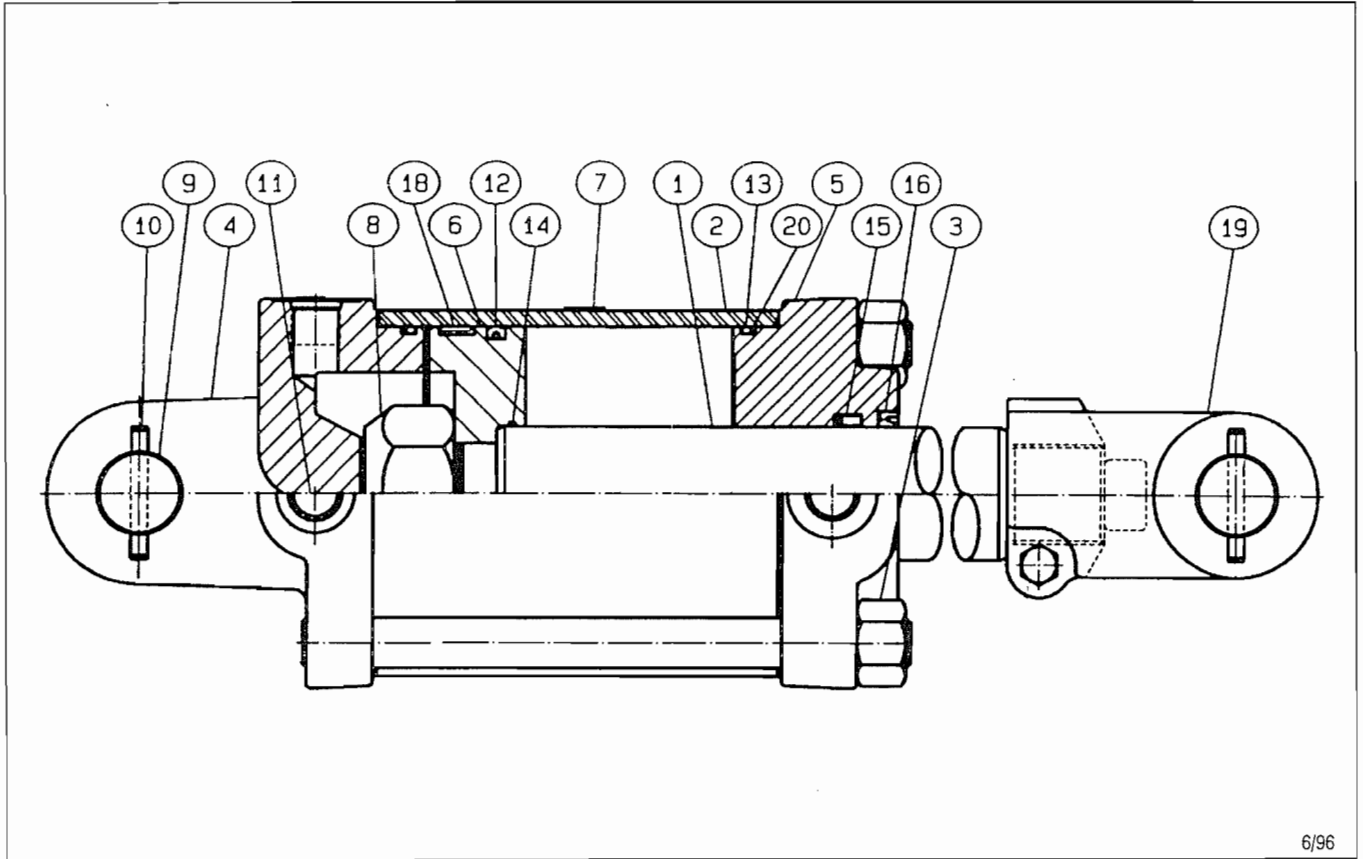

6/96

21-177 5" X 16"
Retracted - 31-1/2"

HYDRAULIC CYLINDER ASSEMBLY
Extended - 47-1/2" Stroke - 16"

7/97
Rod Diameter - 2"

Item	Part Number	Part Description	Qty.
1	21-914	Piston Rod	1
2	21-915	Tube	1
3	21-916	Tie Rod Assembly	4
4	21-868	Butt	1
5	21-869	Gland	1
6	21-870	Piston	1
7	74-113	Cylinder WARNING Decal	1
8	21-871	Lock Nut	1
9	21-872	Clevis Pin	2
10	21-860	Roll Pin	4
11	21-831	Plug	3
12	★	Crown Seal	1
13	★	O-Ring	2
14	★	O-Ring	1
15	★	U-Cup	1
16	★	Wiper	1
17			
18	★	Bearing Ring	1
19	21-865	Clevis Assembly	1
20	★	Back-Up Washer	2
	21-858	Seal Kit (★ Items Included in Kit)	

EATON HYDRAULIC CYLINDER ASSEMBLY

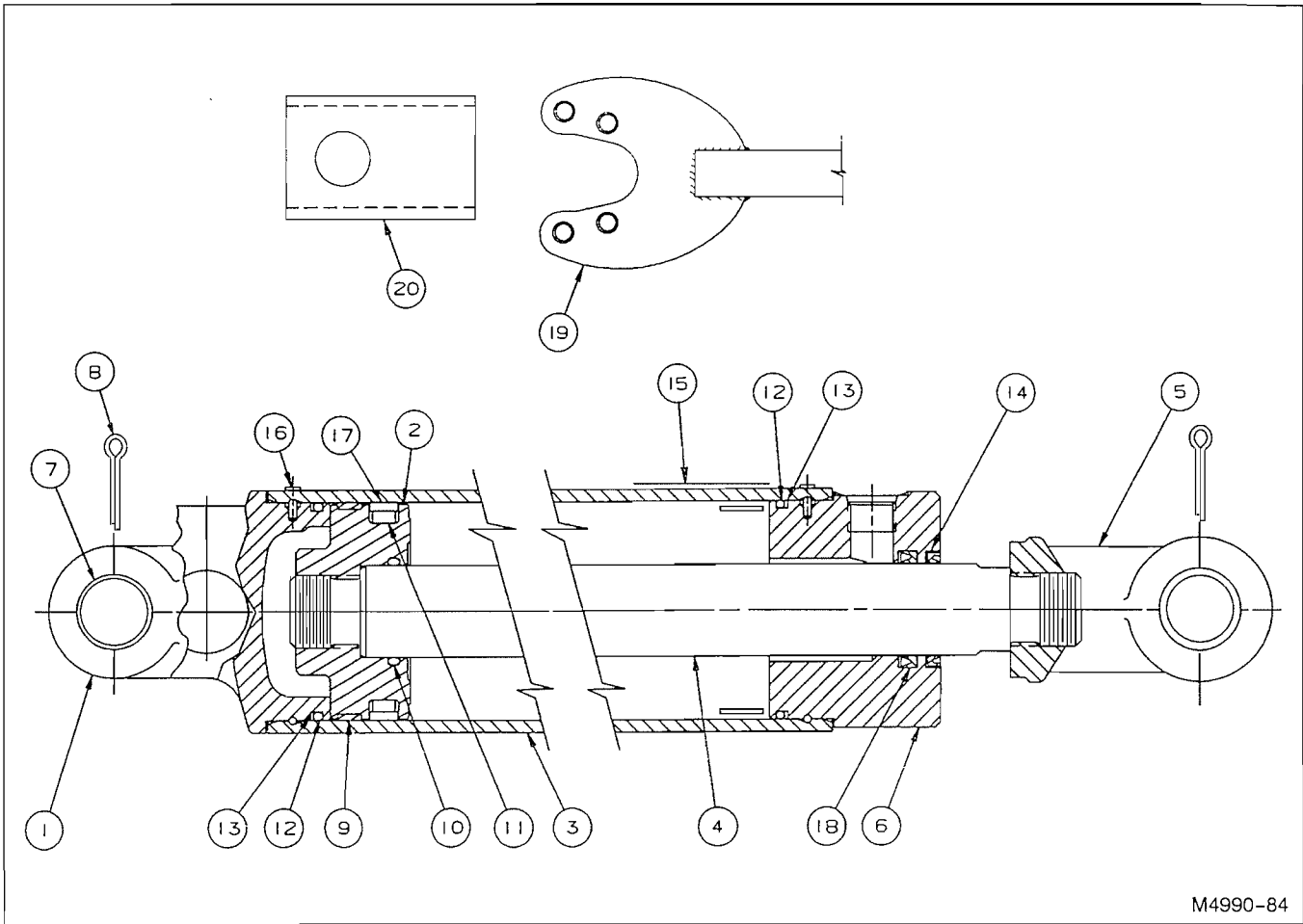

22-127 3-1/2" X 12" EATON HYDRAULIC CYLINDER ASSEMBLY (SERIES)

7/97

Retracted - 24-1/4"

Stroke - 12"

Extended - 36-1/4"

Rod - 1-1/4"

Item	Part Number	Part Description	Qty.
1	22-500	Head	1
2	22-618	Piston	1
3	22-577	Barrel	1
4	22-578	Piston Rod	1
5	22-504WS	Rod End	1
6	22-505	Bearing	1
7	22-508	Clevis Pin	2
8	22-423	Cotter Pin	2
9	*	Wear Ring	1
10	*	O-Ring	1
11	*	Loader Ring	1
12	*	O-Ring	2
13	*	Back-Up Washer	2
14	*	Wiper Seal	1
15	74-113	Cylinder Warning Decal	1
16	*	Lock Ring	2
17	*	Slipper Ring	1
18	*	Rod Seal	1
	• 22-634	Seal Kit (* Items Included in Kit)	
	• 4901-79-0	Cessna Cylinder Tool Kit (For Repairs ONLY)	1
19		Spanner Wrench	1
20		Clevis Stop	1
	•	Not included in Hydraulic Cylinder Assembly	

EATON HYDRAULIC CYLINDER ASSEMBLY

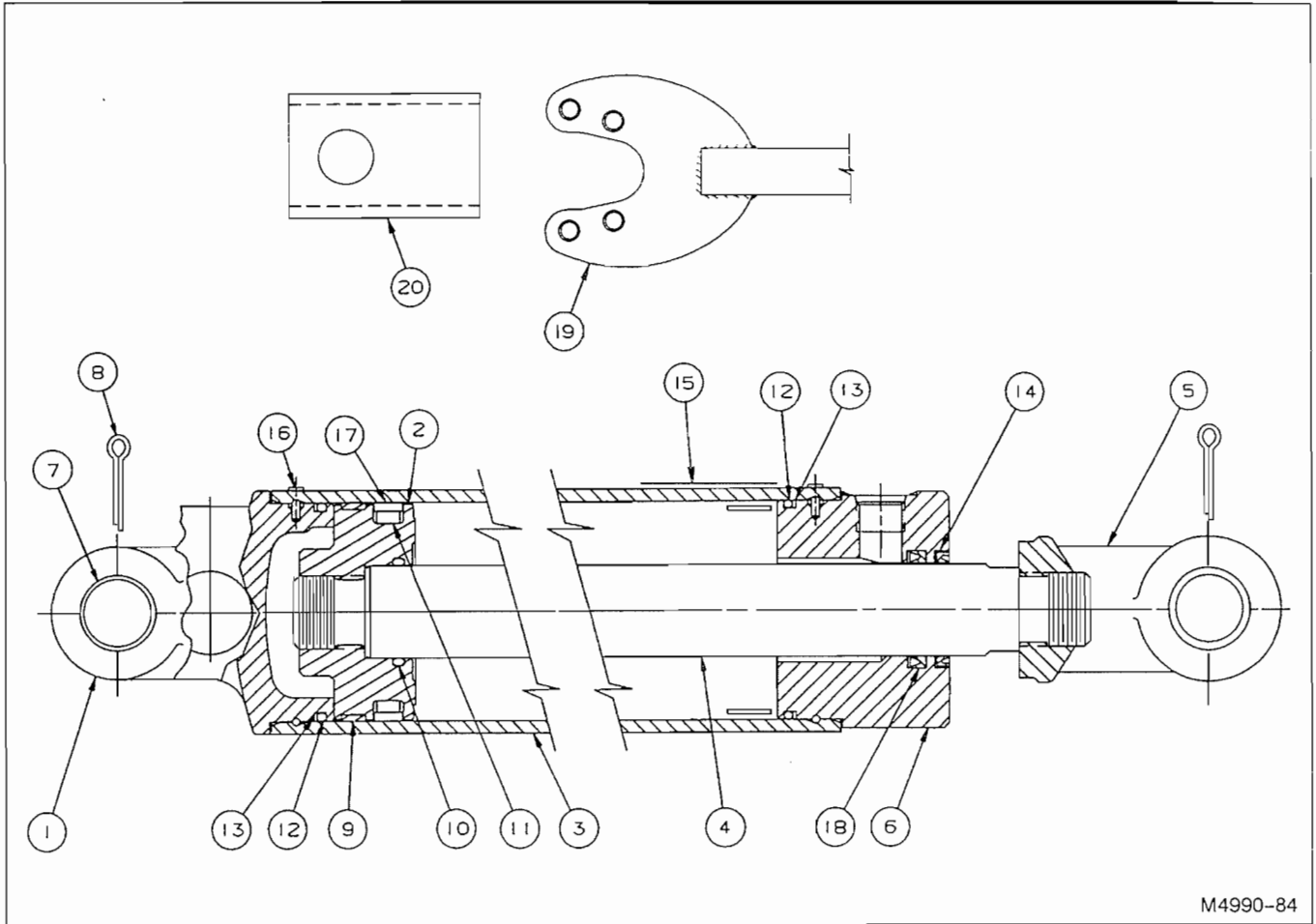

M4990-84

22-128 3-3/4" X 12" EATON HYDRAULIC CYLINDER ASSEMBLY (SERIES)

7/97

Retracted - 24-1/4"

Stroke - 12"

Extended - 36-1/4"

Rod - 1-3/8"

Item	Part Number	Part Description	Qty.
1	22-509	Head	1
2	22-626	Piston	1
3	22-579	Barrel	1
4	22-625	Piston Rod	1
5	22-513WS	Rod End	1
6	22-514	Bearing	1
7	22-508	Clevis Pin	2
8	22-423	Cotter Pin	2
9	*	Wear Ring	1
10	*	O-Ring	1
11	*	Loader Ring	1
12	*	O-Ring	2
13	*	Back-Up Washer	2
14	*	Wiper Seal	1
15	74-113	Cylinder Warning Decal	1
16	*	Lock Ring	2
17	*	Slipper Ring	1
18	*	Rod Seal	1
	• 22-636	Seal Kit (* Items Included in Kit)	
	• 4901-79-0	Cessna Cylinder Tool Kit (For Repairs ONLY)	1
19		Spanner Wrench	1
20		Clevis Stop	1
	• Not included in Hydraulic Cylinder Assembly		

EATON HYDRAULIC CYLINDER ASSEMBLY

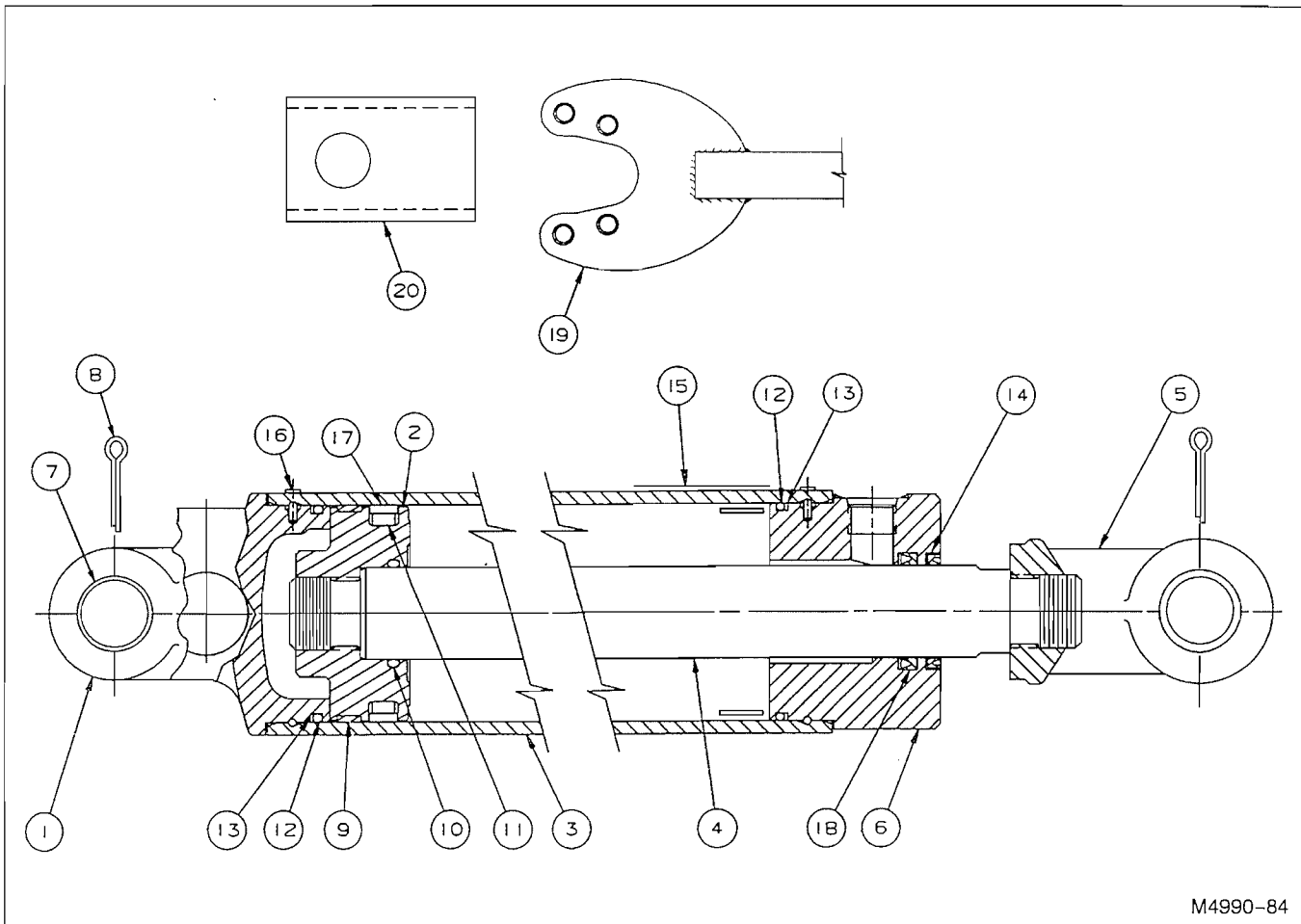

M4990-84

22-129 4" X 12" EATON HYDRAULIC CYLINDER ASSEMBLY (SERIES)

7/97

Retracted - 24-1/4"

Stroke - 12"

Extended - 36-1/4"

Rod - 1-3/8"

Item	Part Number	Part Description	Qty.
1	22-517	Head	1
2	22-602	Piston	1
3	22-581	Barrel	1
4	22-610	Piston Rod	1
5	22-521WS	Rod End	1
6	22-522	Bearing	1
7	22-508	Clevis Pin	2
8	22-423	Cotter Pin	2
9	*	Wear Ring	1
10	*	O-Ring	1
11	*	Loader Ring	1
12	*	O-Ring	2
13	*	Back-Up Washer	2
14	*	Wiper Seal	1
15	74-113	Cylinder Warning Decal	1
16	*	Lock Ring	2
17	*	Slipper Ring	1
18	*	Rod Seal	1
	• 22-637	Seal Kit (* Items Included in Kit)	
	• 4901-79-0	Cessna Cylinder Tool Kit (For Repairs ONLY)	1
19		Spanner Wrench	1
20		Clevis Stop	1
	• Not included in Hydraulic Cylinder Assembly		

DECALS & REFLECTORS

FOR MODELS – ALL

1/93

Item	Part Number	Part Description	Qty.
1	74-100	KRAUSE Decal	1
2	74-101	KRAUSE Decal	1
3	74-102	WARNING – Hydraulic Safety Decal	6
4	74-107	Amber Reflector	8
5	74-108	Red Reflector	8
6	74-162	K-Tine Decal	1
7	74-383	5650 SERIES Decal	1
8	74-158	Rear Jack Stand Decal	1
9	74-117	Implement Safety Decal	1
10	74-121	WARNING – Transport Width / Height Decal	1
11	74-276	WARNING – Hydraulic Safety Decal	1
12	74-394	Depth Adjustment Decal	2
13	74-393	WARNING – Lock Valve Decal	1

LIGHT KIT

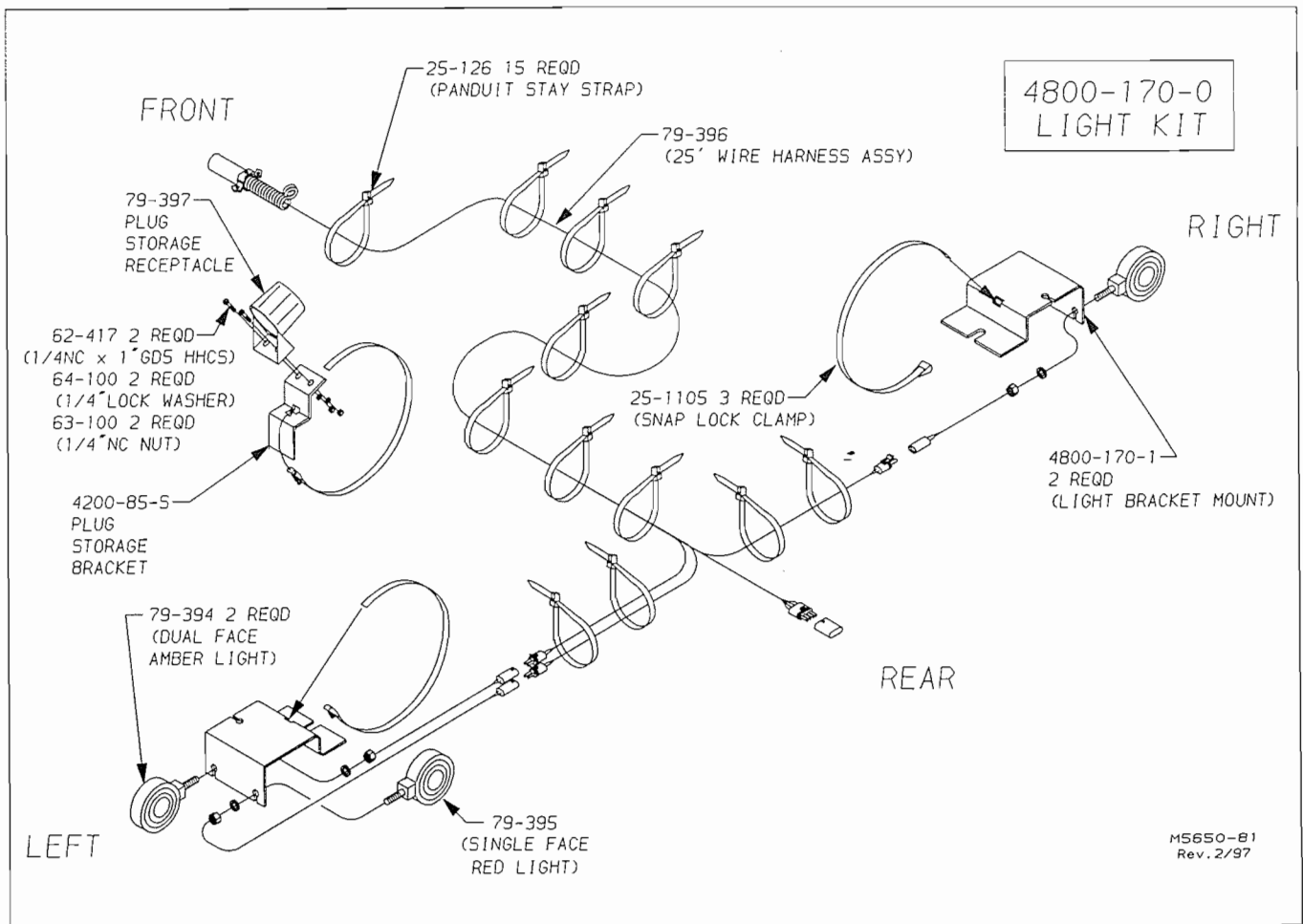

M5650-81
Rev. 2/97

TRAIL HITCH ASSEMBLY

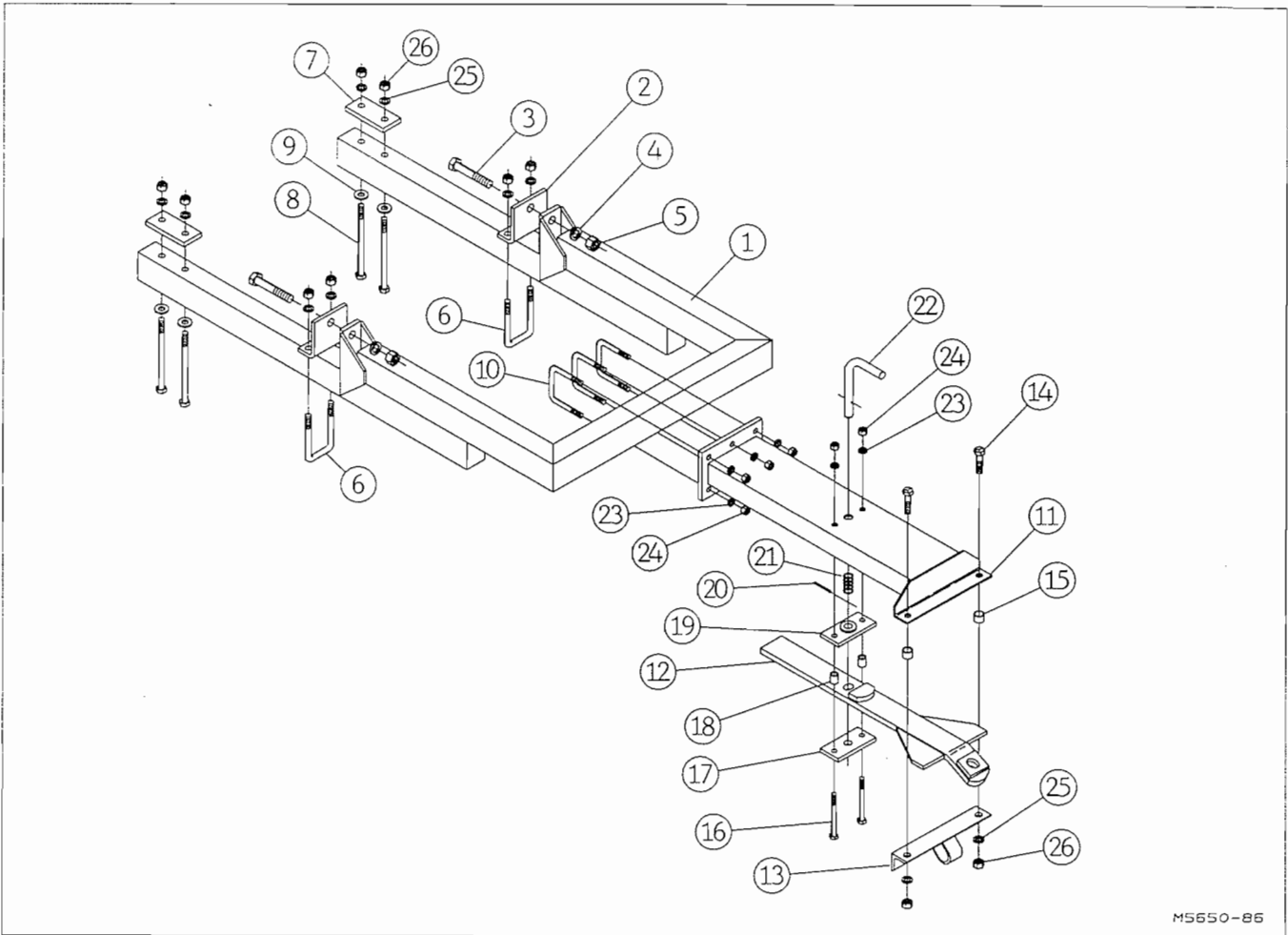

FOR MODELS - ALL

8/97

Item	Part Number	Part Description	Qty.	Item	Part Number	Part Description	Qty.
	5648-401-0	Hitch Extension Assembly	1	17	3755-302-2	Pin Guide	1
1	5648-402-0	Hitch Frame Weldment	1	18	3755-302-3	Spacer	2
2	4223-401-6	Angle Bracket	2	19	3755-305-0	Pin Guide Weldment	1
3	62-504	1NC x 5-1/2" GD5 Cap Screw	2	20	60-606	1/4" DIA. x 2" Roll Pin	1
4	64-118	1" STD. Lock Washer	2	21	76-137	Spring	1
5	63-117	1NC Hex Nut	2	22	3755-302-1	Spring Pin	1
6	61-207	3/4" DIA. U-Bolt	2	23	64-109	5/8 STD. Lock Washer	8
7	3127-571-1	Bolt Plate	2	24	63-109	5/8NC Hex Nut	8
8	62-225	3/4NC x 10" GD5 Machine Bolt	4	25	64-112	3/4" STD. Lock Washer	10
9	64-113	3/4" STD. Flat Washer	4	26	63-112	3/4NC Hex Nut	10
10	61-126	5/8" DIA U-Bolt	3				
	3755-302-0A	Trail Hitch Assembly	1				
11	3755-303-0A	Hitch Frame Weldment	1				
12	3755-304-0A	Swing Tongue Weldment	1				
13	3755-307-0	Angle Support Weldment	1				
14	62-195	3/4NC x 2-1/2" GD5 Cap Screw	2				
15	3755-302-4	Spacer	2				
16	62-393	5/8NC x 6" GD5 Cap Screw	2				

ASSEMBLY SECTION

THE FOLLOWING SECTION ILLUSTRATES A GENERAL METHOD FOR THE ASSEMBLY OF THIS SERIES KRAUSE TILLAGE TOOL. YOU MUST KNOW THE MODEL NUMBER OF THE UNIT BEING ASSEMBLED WHENEVER MAKING REFERENCE TO THIS SECTION. THE FOLLOWING PICTURES AND DRAWINGS WILL SHOW BOLTS, PINS, NUTS AND ETC., WITH THE DESCRIPTIVE SIZE AND LENGTHS IN THE ACCOMPANYING PARAGRAPH AND A PARTS LISTING REFERENCE PAGE NUMBER. IF ANY DIFFICULTY SHOULD BE ENCOUNTERED DURING THE ASSEMBLY, RECHECK THE ILLUSTRATIONS, ASSEMBLY STEPS AND PARTS LIST DRAWINGS.

PROPER BOLT USE

DO NOT use these values if a different torque value or tightening procedure is given for a specific application. Torque values listed are for general use only. Check tightness of fasteners periodically.

Shear bolts are designed to fail under predetermined loads. Always replace shear bolts with identical grade.

Fasteners should be replaced with the same or higher grade. If higher grade fasteners are used, these should only be tightened to the strength of the original.

Tighten plastic insert or crimped steel-type lock nuts to approximately 110 percent of the dry torque shown in the chart, applied to the nut, not to the bolt head. Tighten toothed or serrated-type lock nuts to the full torque value.

NOTE: "Lubricated" means coated with a lubricant such as engine oil, or fasteners with phosphate and oil coatings. "Dry" means plain or zinc plated without any lubrication.

BOLT SIZE	BLACK OR PLATED BOLTS		OILED BOLTS	
	GRADE 2	GRADE 5	GRADE 2	GRADE 5
3/8"	20	33	16	26
7/16"	32	52	26	41
1/2"	50	80	39	63
5/8"	100	160	78	125
3/4"	175	280	140	225
7/8"	175	450	140	360
1"	270	675	210	540
1-1/8"	375	850	300	675
1-1/4"	530	1200	425	950
1-1/2"	930	1400	725	1250
TIE ROD TIGHTENING TORQUE				
1-1/2" Dia. Rods		1000 Ft. Lbs.		
1-3/4" Dia. Rods		1400 Ft. Lbs.		
2" Dia. Rods		1600 Ft. Lbs.		

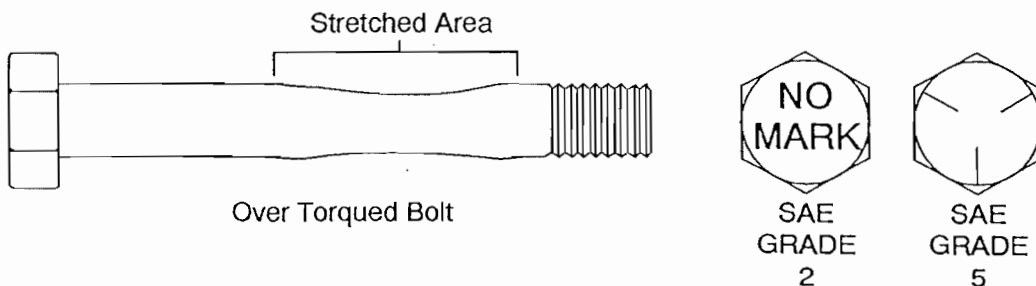

WARNING

**AVOID BODILY INJURY
FROM FALLING FRAMES**

**ALWAYS SUPPORT FRAMES WITH
UNLOADING EQUIPMENT BEFORE
RELEASING TRUCK SECUREMENT**

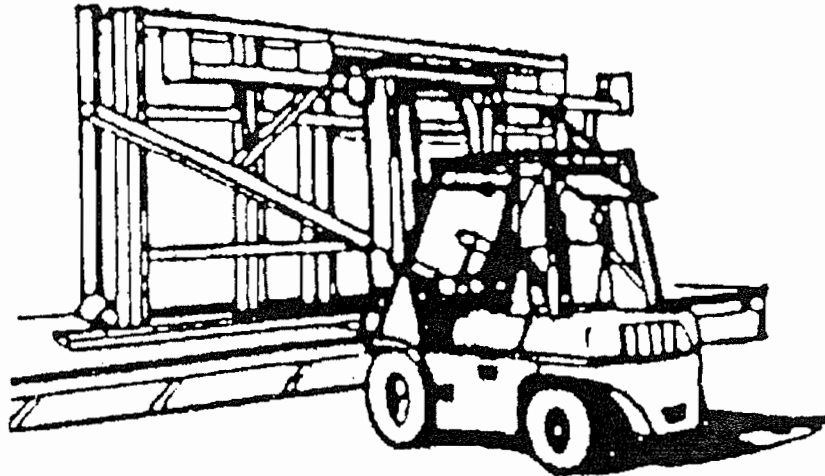

**STORE AND DISASSEMBLE IN A
HORIZONTAL POSITION ONLY**

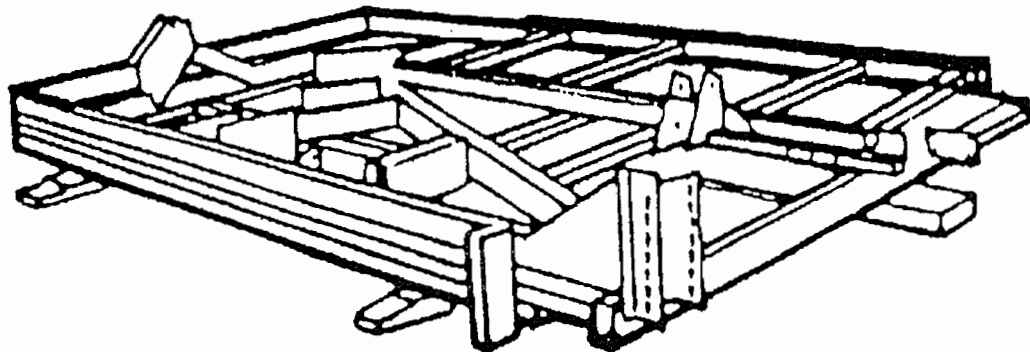



ASSEMBLY INSTRUCTIONS

STUDY THE NAMES AND LOCATIONS OF THE PARTS FROM THE PARTS SECTION OF THIS MANUAL AND FAMILIARIZE YOURSELF WITH THE FIELD CULTIVATOR BEFORE STARTING THE ASSEMBLY. READING THE STEP BY STEP INSTRUCTIONS THAT FOLLOW WILL BE HELPFUL.

SAFETY



READ ALL THE SAFETY NOTATIONS IN THE ASSEMBLY INSTRUCTIONS THAT FOLLOW FOR YOUR OWN PROTECTION. ACCIDENTS CAN BE PREVENTED BY RECOGNIZING THE CAUSE OF AN ACCIDENT BEFORE IT CAN HAPPEN.

ASSEMBLY

Select an area for the assembly that will be large enough to accommodate the completed field cultivator. The surface of the work area should be as level as possible. Use the proper hand tools to insure proper bolt tightness. Refer to the page titled "Proper Bolt Use" for the recommended torque values of different size bolts.

PART LOCATIONS

FRONT – The front of the frame can be determined by the location of the name plate that has been attached to the front frame member.

RIGHT and **LEFT** sides can be established by standing behind the frame and looking toward the front, or the direction of travel.

MODEL NUMBERS

Know the model number of the field cultivator being assembled. Use the model number whenever referring to the assembly, parts listing pages or placement drawings. The number is stamped on the NAME PLATE located on the front frame member.



ASSEMBLY STEPS

Warning: Always attach chains securely. If a chain would break, the recoil action could cause the loose end to whip in any direction and injure any person nearby.

Proof load rating of chain must equal or exceed 5 times the weight being lifted.

THE HEAVIEST COMPONENT TO BE LIFTED INTO PLACE IS THE CENTER FRAME WHICH WEIGHS 1,300 LBS.

Listed below are the hardware sacks necessary to assemble this unit. A Part Number is on each sack, the list below will tell you where each sack of bolts and parts are to be used.

66-821	Front Frame	66-822	Hitch
66-823	Inside Wing Hinge	5648-63-0	Depth Stop Adjustment
5648-62-0	Front Wing Frame	5660-62-0	Front Wing Frame
5660-69-0	Shank Extensions	5660-61-0	Inner Wing
5660-60-0	Main Frame	5660-65-0	Front Inside Frame
5660-64-0	Gauge Wheels	5660-67-0	Inside Wing Lift
5660-66-0	Tongue	5660-69-0	Outer Wing Hinge
5660-68-0	Outside Wing		

Bolt and part sacks not listed are used for shank extension assembly. Plumbing parts and fittings are in the hose sacks.

IMPORTANT: THE PHOTOS IN THE ASSEMBLY SECTION WILL SHOW YOU LOCATIONS OF PARTS. REFER TO THE PARTS SECTIONS FOR PART AND HARDWARE DESCRIPTIONS.

Place main frame and rocker assembly on stands approximately 30" high. Loosely bolt front main frame to MAIN FRAME 1.

⚠ Caution: Main frame is heavy and may fall if not properly support causing serious injury or death to you or others. Put supports underfront end of hitch tubes.

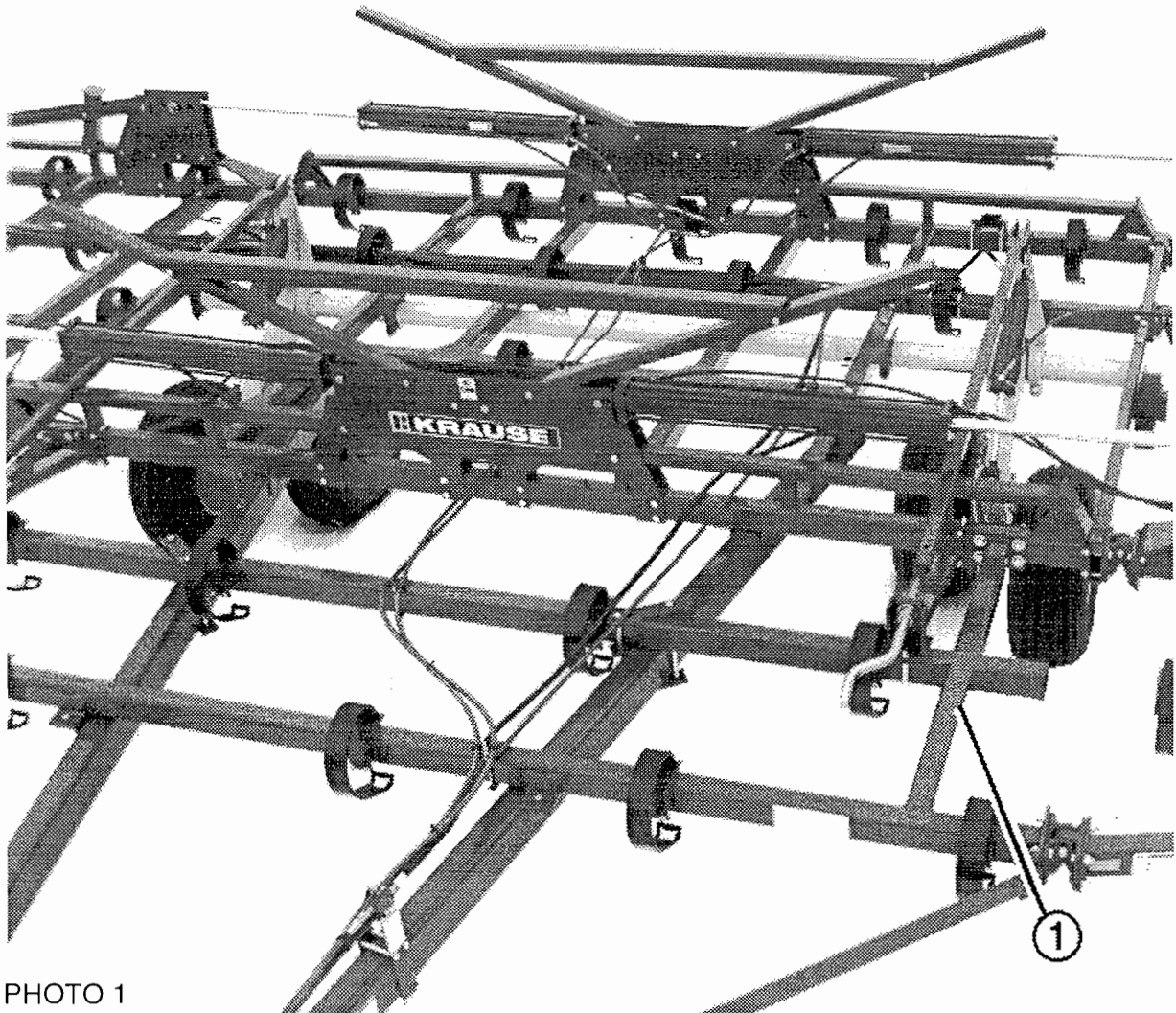
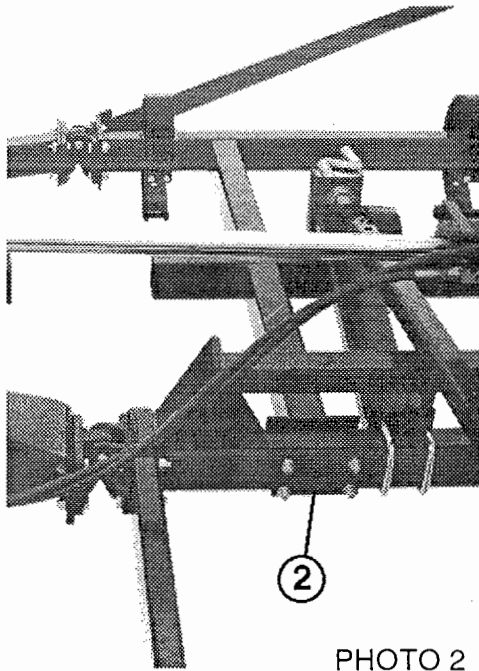
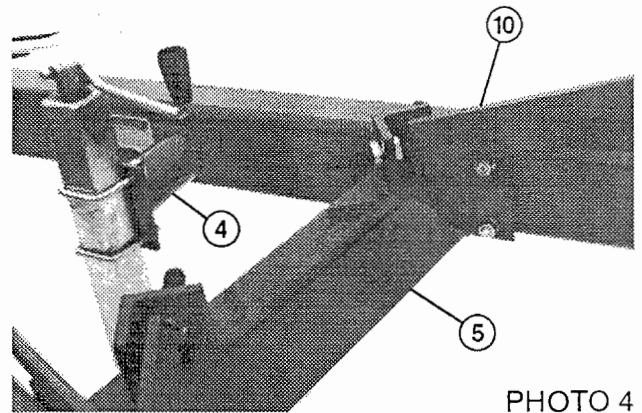
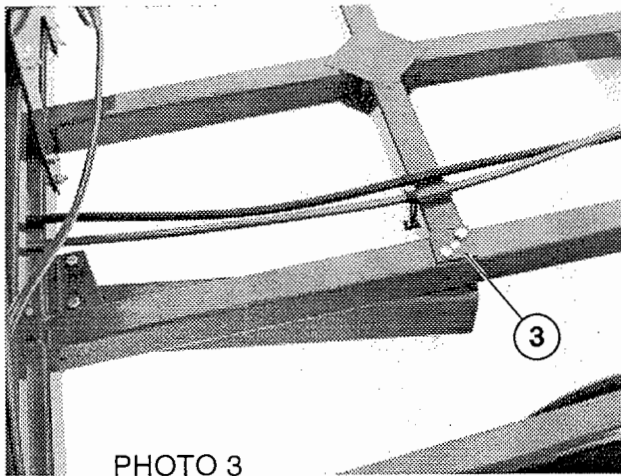

PHOTO 1



Use plate back of CENTER FRAME 2.

Loosely bolt TONGUE TUBES under main frame and front main frame — use plate on top of FRAME 3. NOTE: The tongue tube with the jack support tube bolts on the right side of the FRAME 4 with jack tube to the inside.



Bolt SPACER TUBE between tongue tubes 5.

Bolt HITCH BRACKET 6 to tongue tubes. A shim is provided to place between hitch bracket and tongue tubes if necessary.

Pin CLEVIS HITCH 7 and SAFETY CHAIN 8 to hitch bracket.

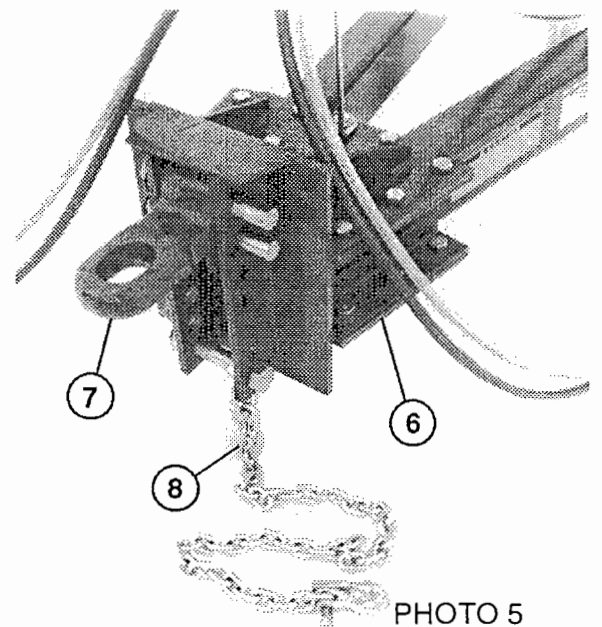

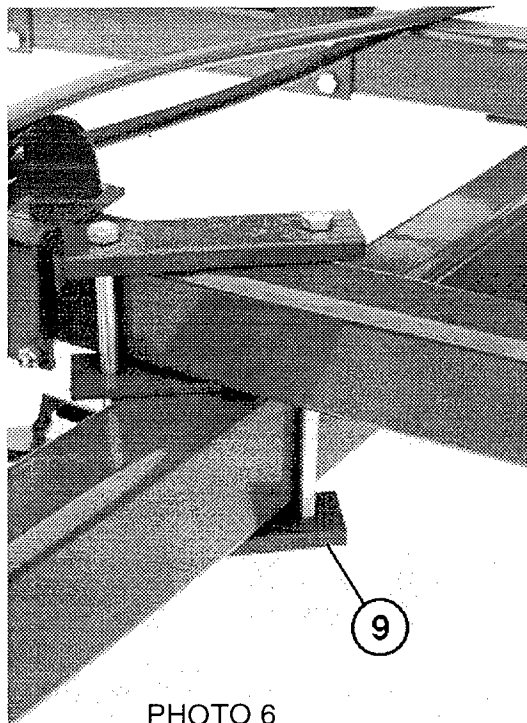

PHOTO 6

Finish bolting tongue tubes to front main frame 9.
TIGHTEN ALL BOLTS.

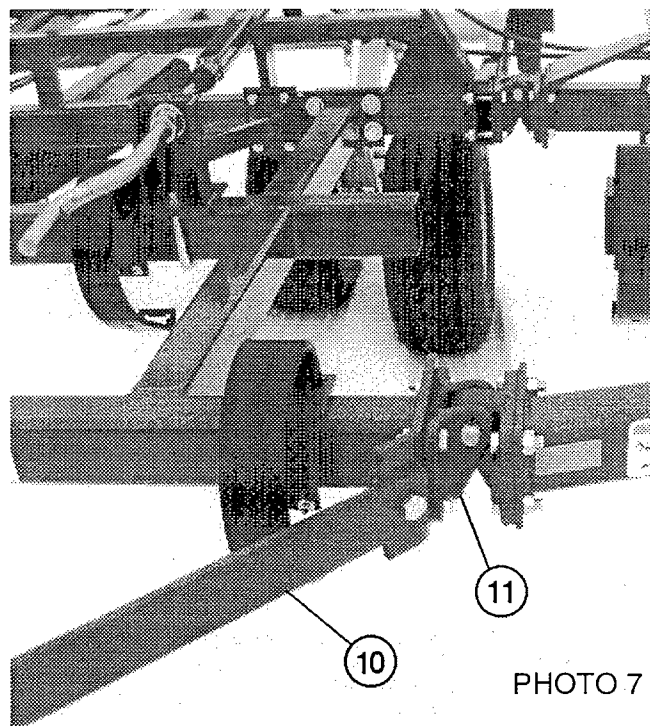

PHOTO 7

Assemble TONGUE BRACE 10 use jam nut on each side of bolt, see photo number 4.

Bolt HINGES 11 to main frame — three on each side.

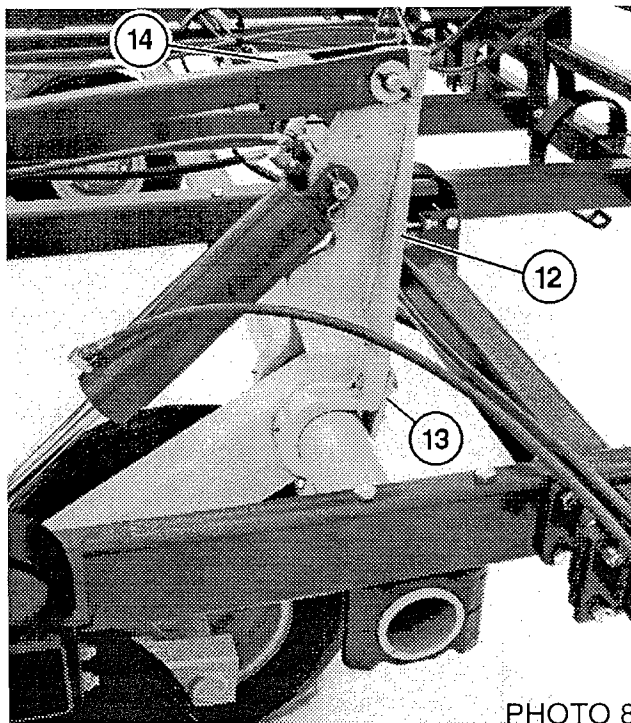

PHOTO 8

Bolt ANCHOR 12 around rocker shaft wheel arm with STRAP 13.

Pin LEVELING TUBE 14 to anchor. Use Flat Washer on each side.

U-Bolt LEVELING TUBE BRACKET 15 to front side of main frame and top side of front frame.
Assemble CRANK 16 into TUBE 14.

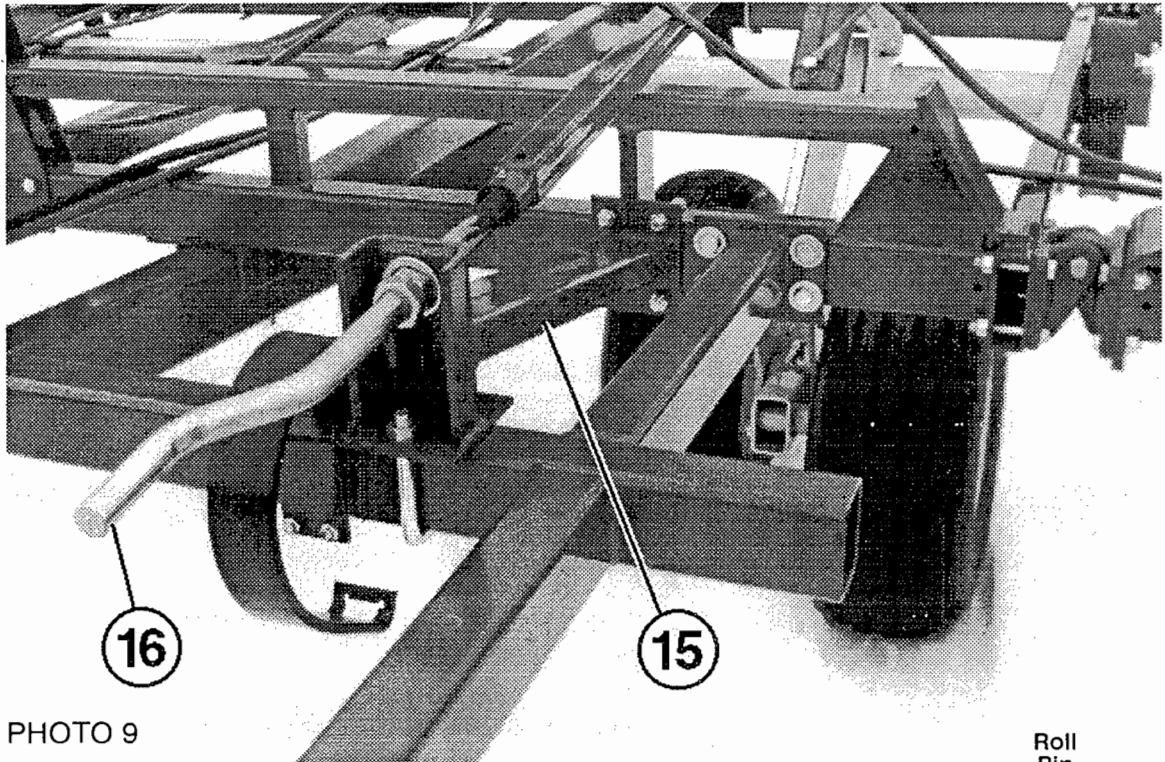
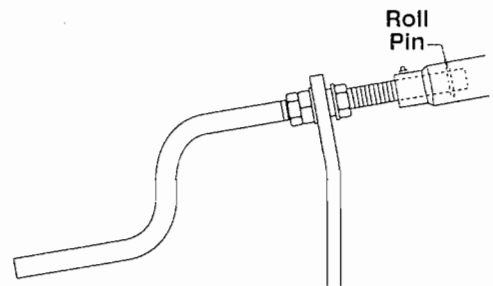

PHOTO 9

⚠ Caution: It is very important that ALL cranks are secured inside the leveling tubes with a roll pin.



See photo number 17 for placement of spacer tube, Washers and Nuts. After the crank is assembled with the roll pin in place turn the crank counter-clockwise  as far as it will turn -- repeat this procedure for all six cranks.

PHOTO 10

Bolt WALKING BEAMS to wheel arms. Note location of SPACER TUBE 17. Pin 4 x 12 hydraulic cylinder in place -- place grease fittings in ROCKER ANCHORS 12 and LEVELING TUBE 14. Mount 12.5L x 16, 14-Ply tires to hubs. Tighten wheel bolts to 95 Ft. Lbs. torque.

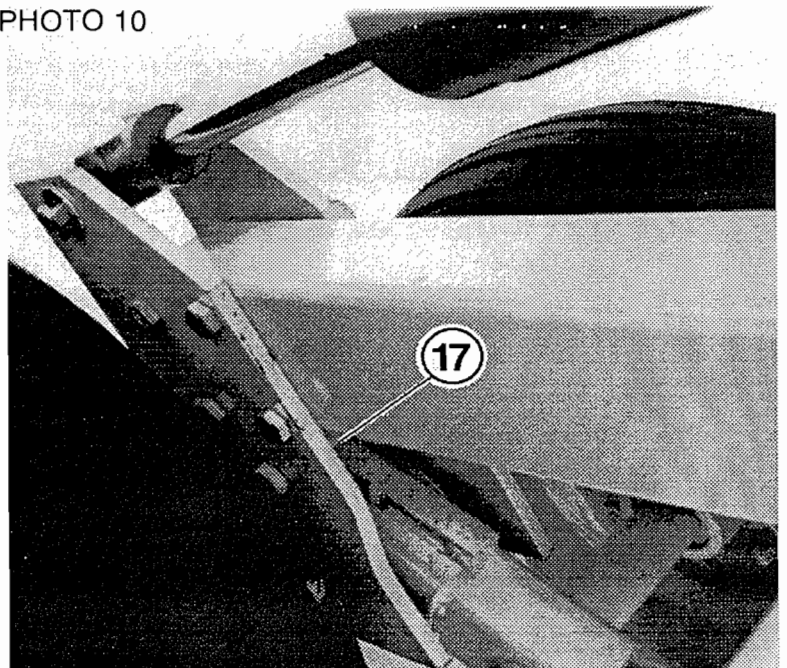

⚠ Warning: When inflating tires, use a clip-on chuck and extension hose long enough to allow you to stand to one side and NOT in front of or over the tire assembly. Use a safety cage if available.

Loosely bolt CYLINDER ANCHOR PLATES 18 to each side of front and rear main frame boxes. Bolt WING STOP TUBES 19 between plates. Bolt CHANNEL 20 to TUBES 19. **TIGHTEN ALL BOLTS.**

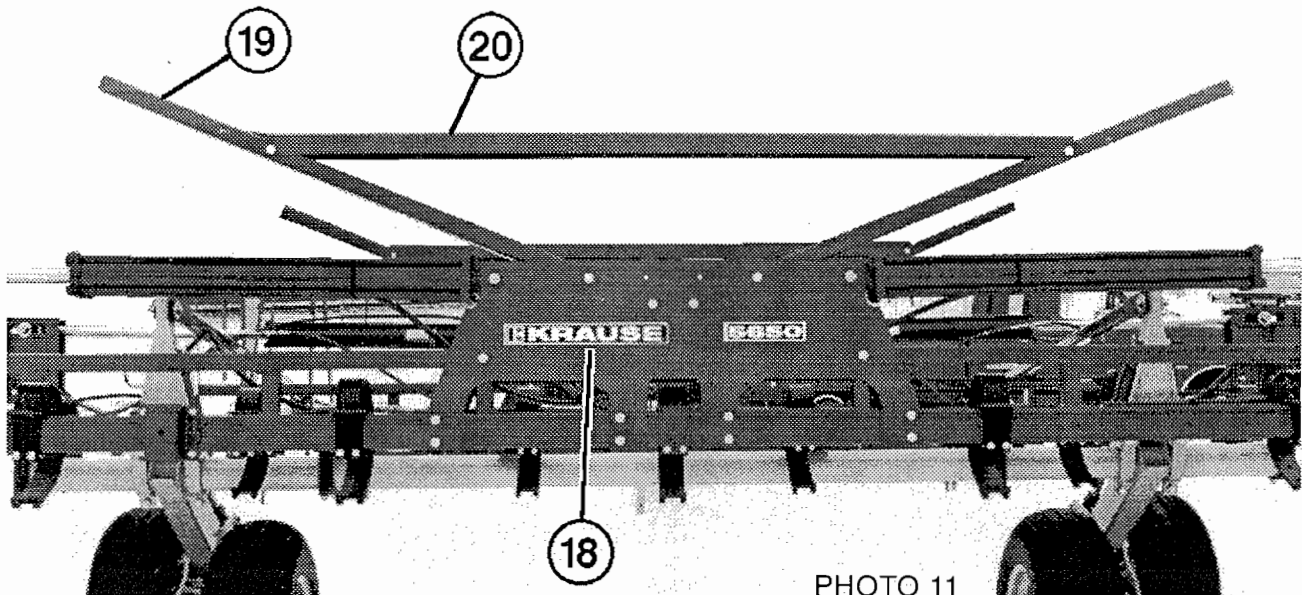

PHOTO 11

The center section should now be complete.

Place inside wings on stands on each side of center section. Loosely assemble WING FRAME SUPPORT 19 to wing frame. Leave bolts loose until FRONT OUTER WING HINGE 39 & 40 are assembled in place to outer wing. See photo number 21.

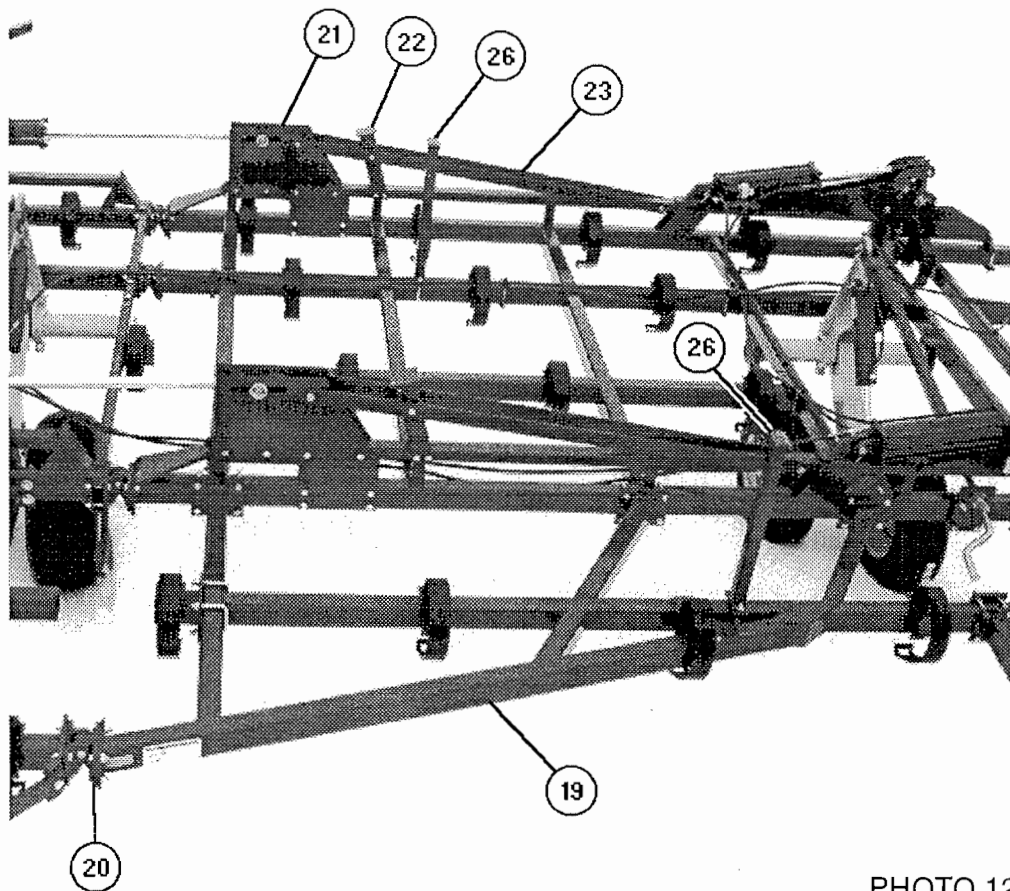

PHOTO 12

Bolt HINGES 20 to wings and pin to center section. See photo number 7.

Loosely bolt PLATES 21 and STOP 22 to front and back of inside wing frame. Bolt STRAPS 23 on outside of PLATES 21 and STOP 22. Note: use two Flat Washers on each side of STOP 22 & 24. **TIGHTEN ALL BOLTS.**

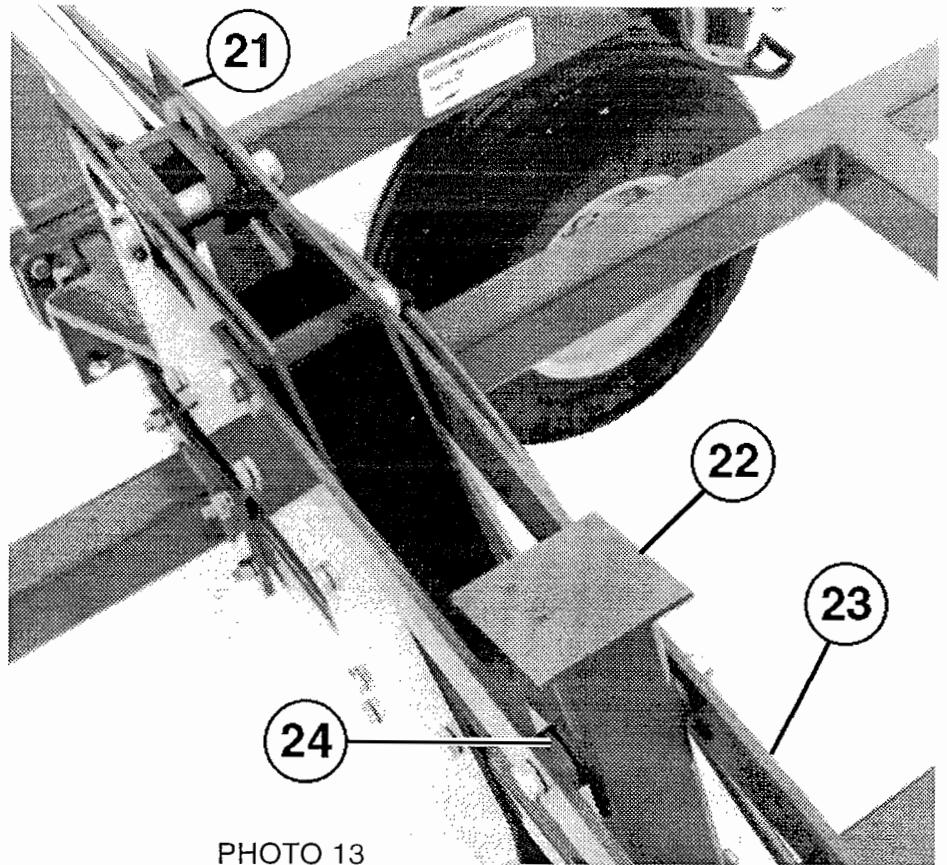
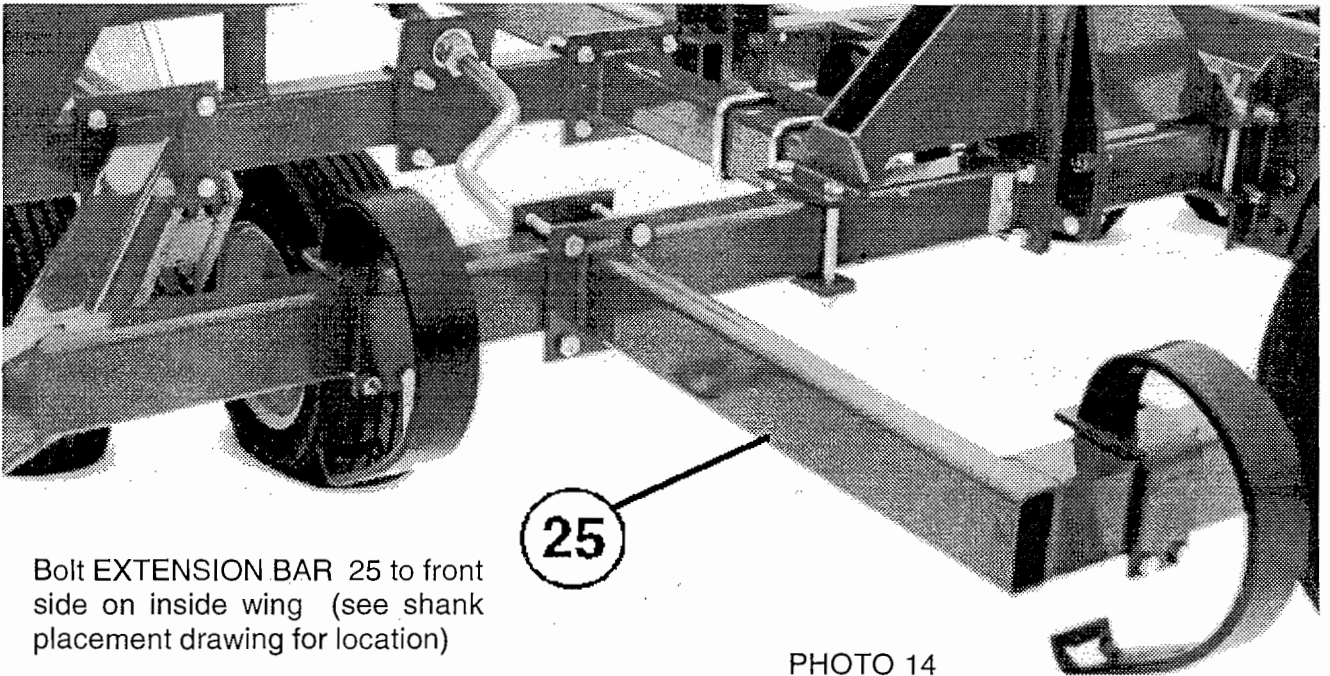

PHOTO 13



Bolt EXTENSION BAR 25 to front side on inside wing (see shank placement drawing for location)

PHOTO 14

Bolt WING STOPS 26 to inside wing frame
(see shank placement drawing for
location)

Bolt CYLINDER ANCHOR 12 to wing
rocker shaft. See photo number 8.

Pin LEVELING TUBE 27 to anchor, use
Flat Washer on each side. See photo
number 8.

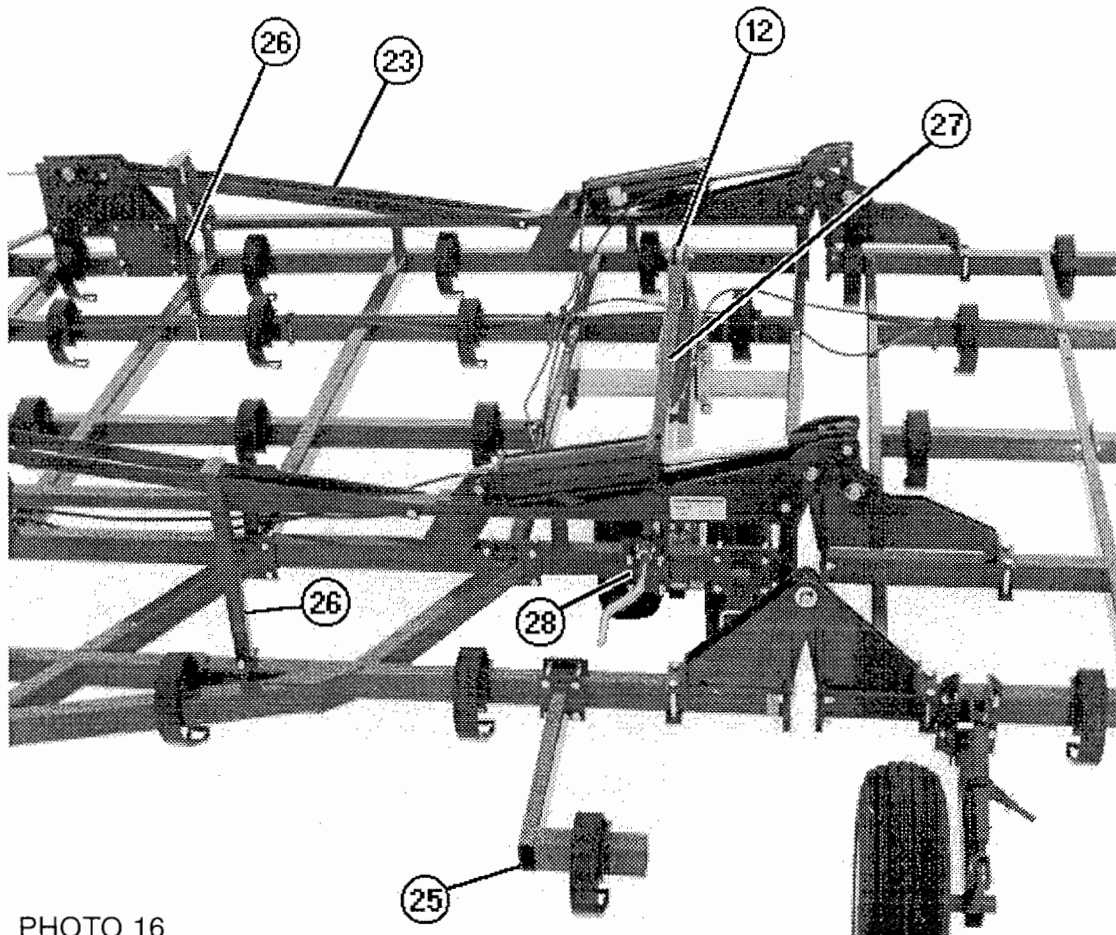
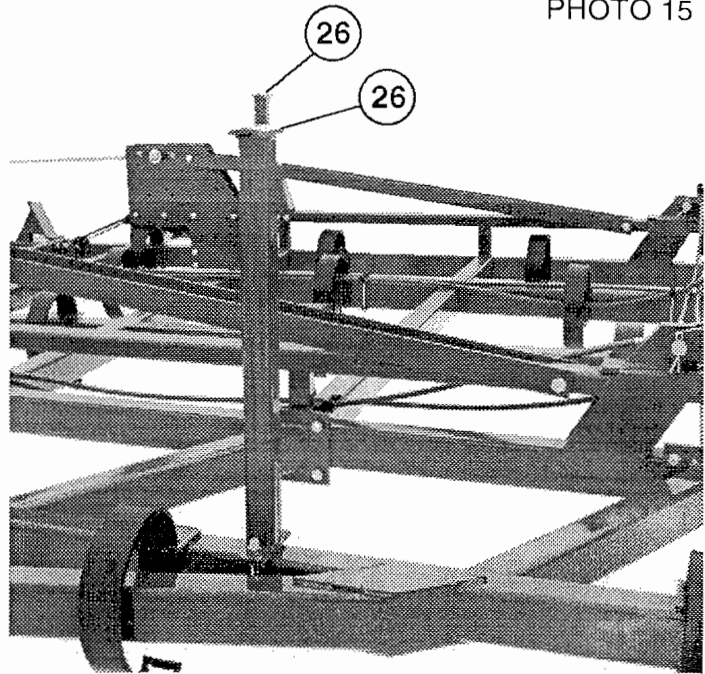

PHOTO 16

U-Bolt BRACKET 28 to front side of wing frame. Assemble CRANK 16 into LEVELING TUBE 27. Place SPACER TUBE 28 over crank — secure with nut 29 on back side and double nuts 30 on front side.

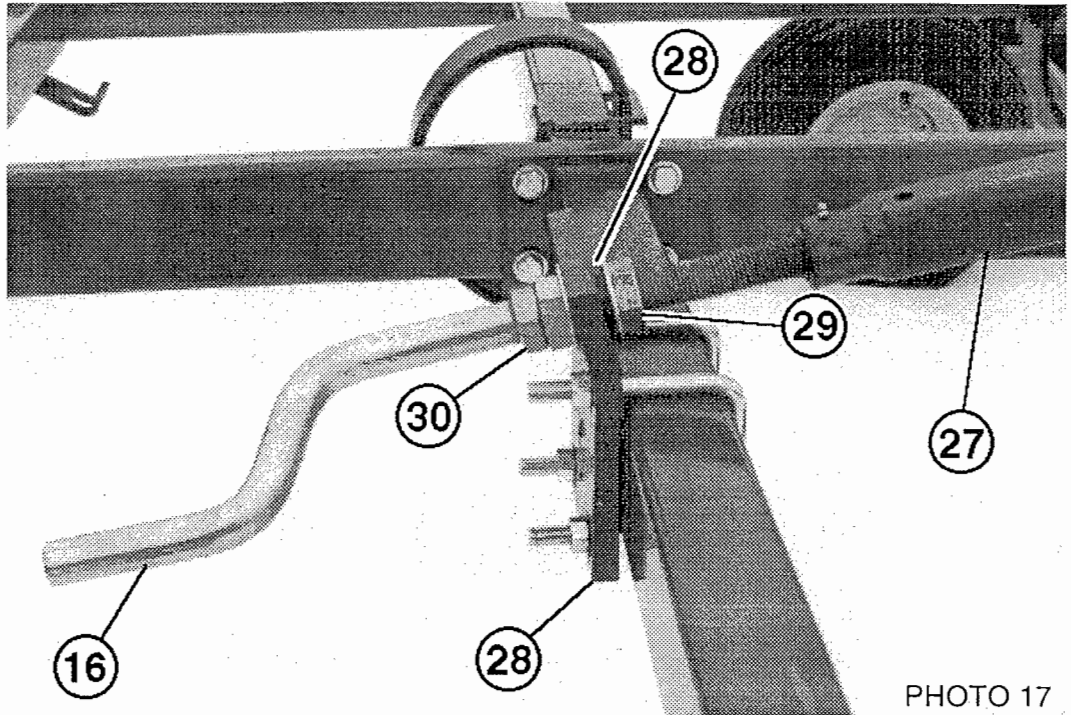
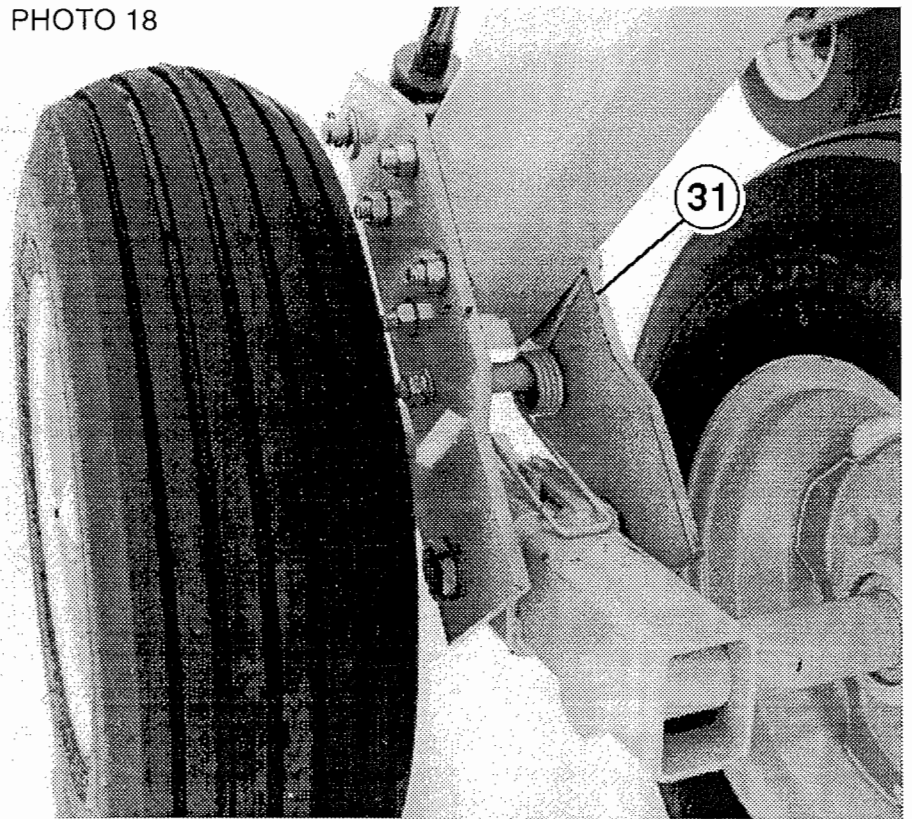

PHOTO 17

PHOTO 18

Bolt WALKING BEAMS 31 to wheel arms. Pin 3-3/4" x 12" Cylinder in place. Place grease fittings in ROCKER ANCHOR 12 and LEVELING TUBES 27. Mount 9.5L x 15 tires to wheel hubs — torque wheel bolts to 95 Ft. Lbs.



Place OUTER WING 32 on stands on either side of inside wing frames.

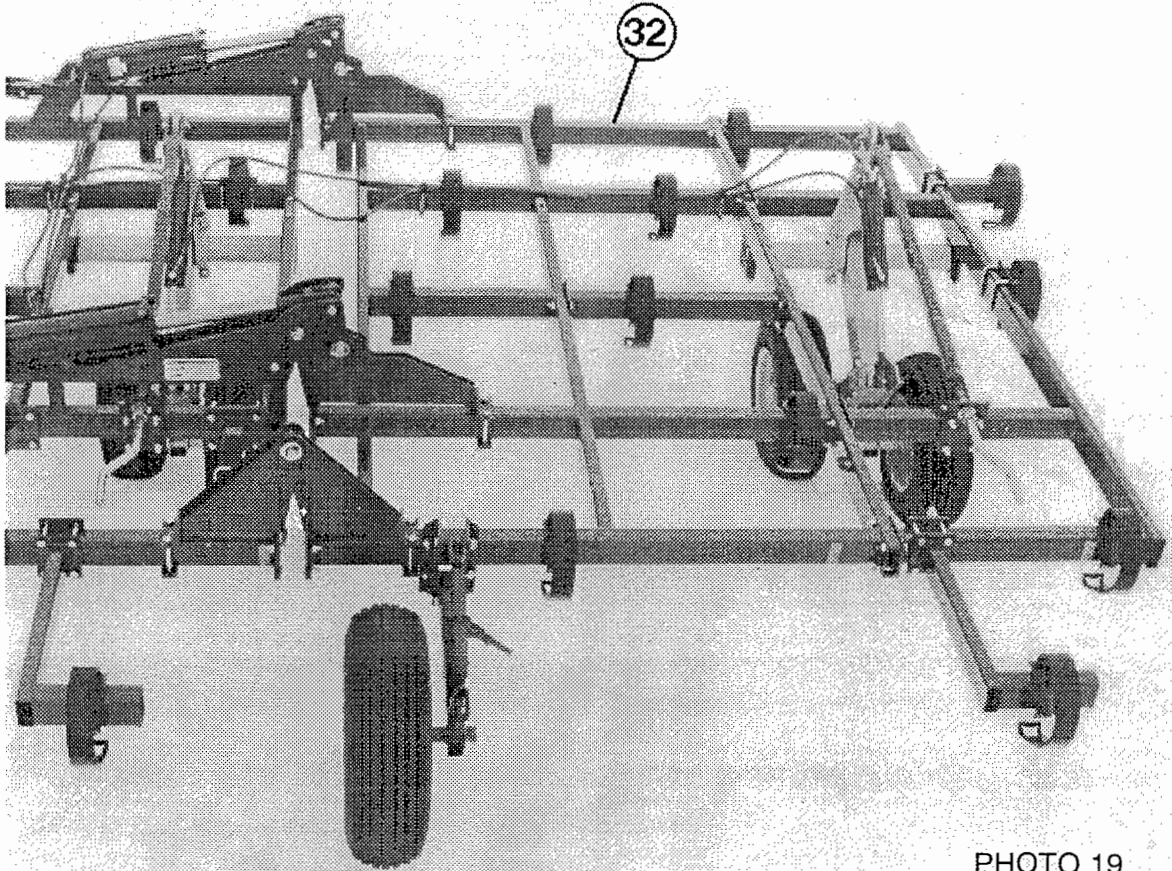
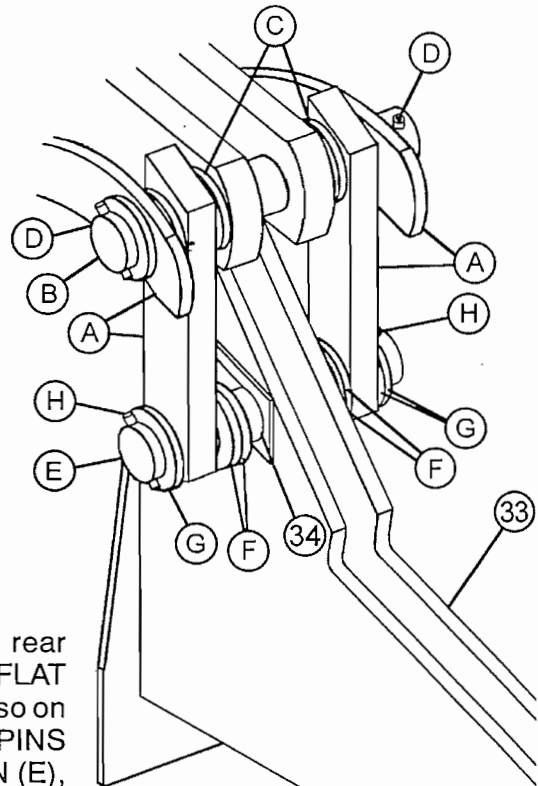
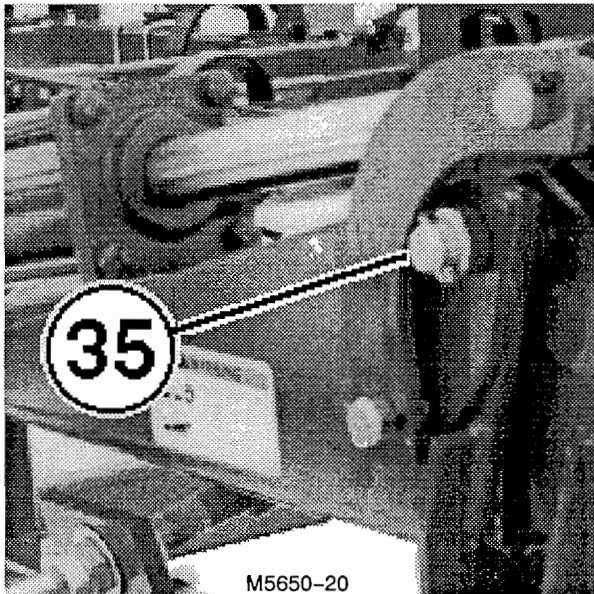

PHOTO 19

Bolt HINGE 33 to rear and center hinge locations of outer wing. Identify part by long slot at 34 . Move hinge and outer wing frame into position and pin to inside wing frame with pin and Two BUSHINGS 35.



M5650-69
Rev.6/96

Loosely assemble LEFT LINKAGE (A) to the center and rear hinge using one 1-1/4" x 8" PIN (B), two 1-1/4" SAE FLAT WASHERS (C) (washers go on *Inner Side* of lift linkage, also on *Inner & Outer SIDE* of curved links), two 3/8" x 2" ROLL PINS (D) on upper part of lift linkage and use one 1-1/4" x 7" PIN (E), four 1-1/4" SAE FLAT WASHERS (F) on *Inner Side* of lift linkage and 1-1/4" SAE FLAT WASHERS (G) on *each Outside* of lift linkage as shown, and two 3/8" x 2" ROLL PINS (H) on lower part of lift linkage.

NOTE: Dimension "C" must be greater than dimension "D" when installing link straps.

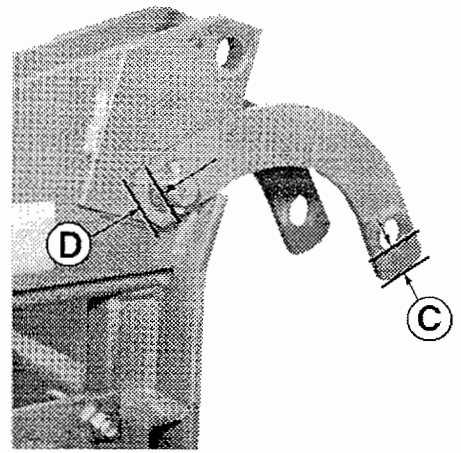

Bolt INSIDE WING HINGE 39 and OUTSIDE WING HINGE 40 to front hinge locations. Align hinges and PIN 41. Tighten WING FRAME SUPPORT BOLTS 42.

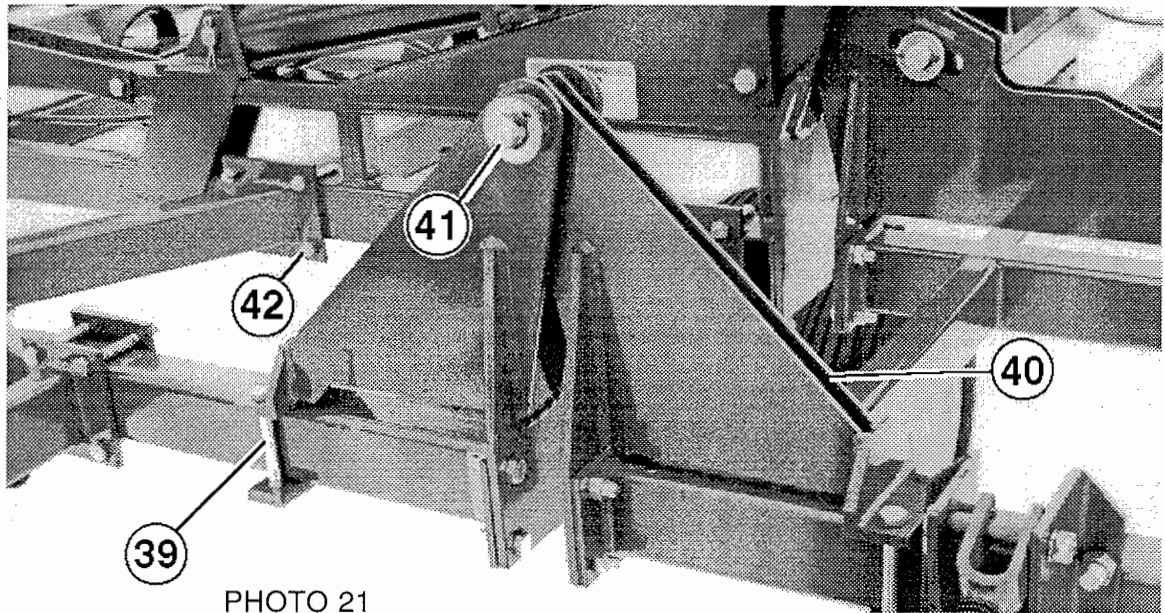
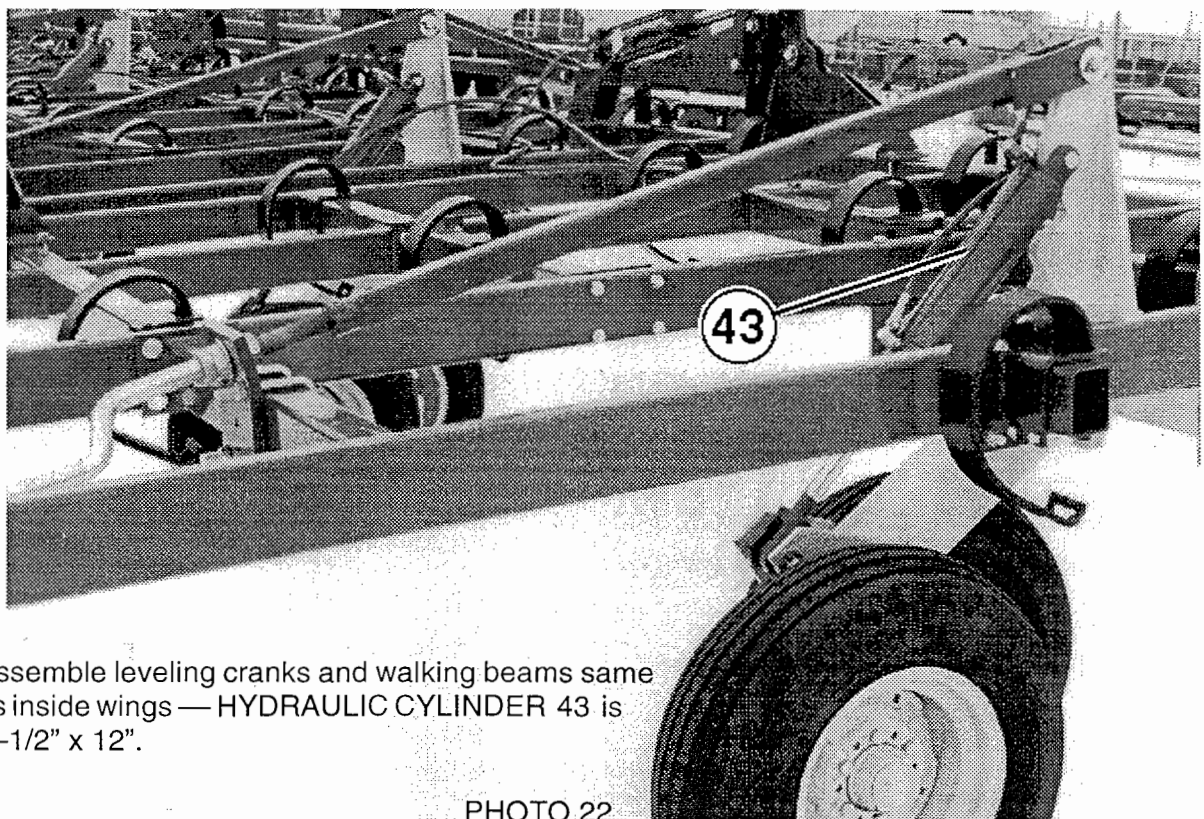

PHOTO 21



Assemble leveling cranks and walking beams same as inside wings — HYDRAULIC CYLINDER 43 is 3-1/2" x 12".

PHOTO 22

Assemble FRONT GAUGE WHEELS 44 to outer wing as close to hinge as possible.

See placement pages at the back of this manual for gauge wheel locations for the model you are setting up.

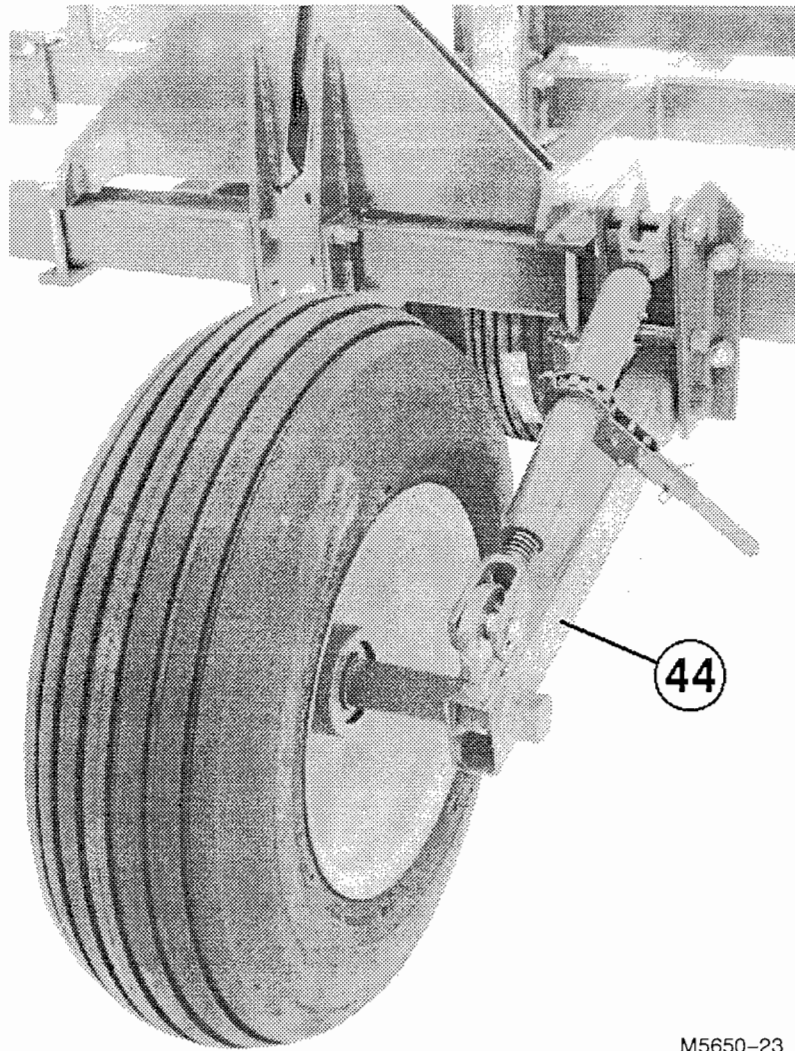

SHANK MOUNTING

See placement pages in the back of this book for shank and shank extension locations.

M5650-23

K-Tine Shanks can be mounted three ways: the four step illustrations below show the rear extended mount.

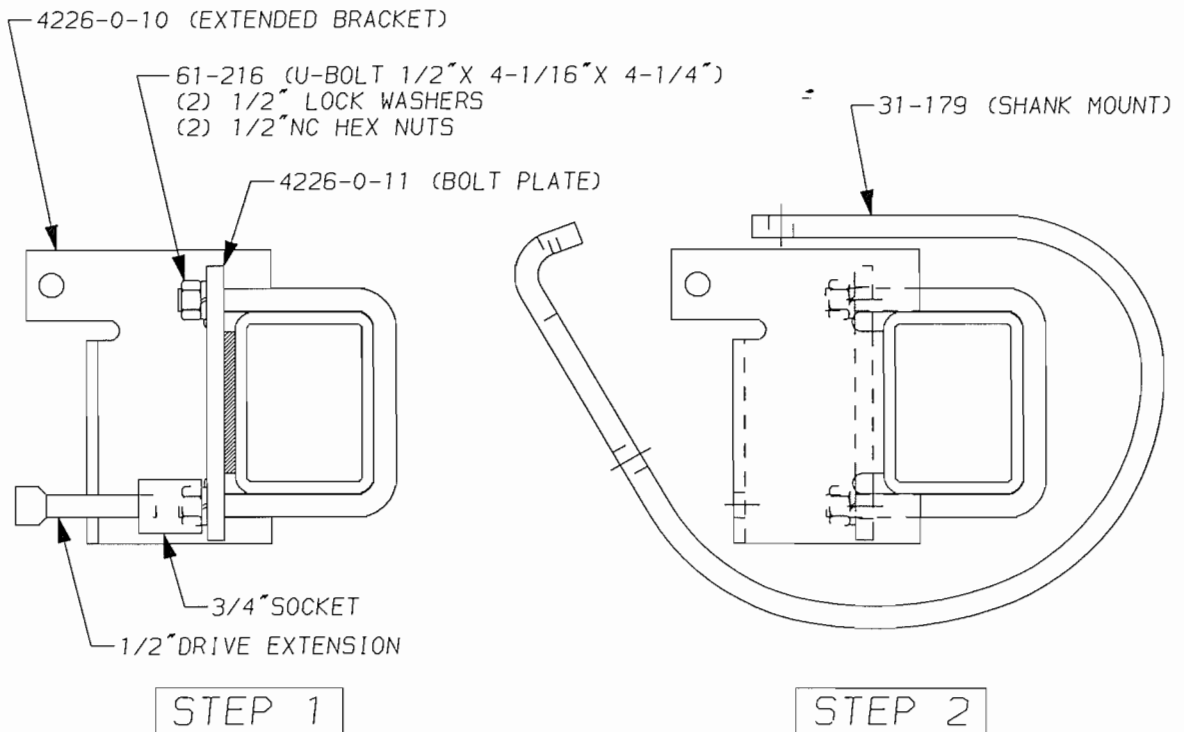

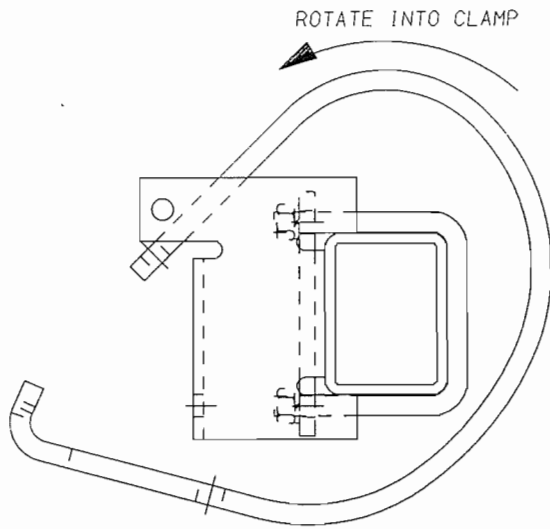

- (2) 1/2"NC X 1-1/2"GDS CAP SCREWS
- (2) 1/2"LOCK WASHERS
- (2) 1/2"NC HEX NUTS

STEP 3

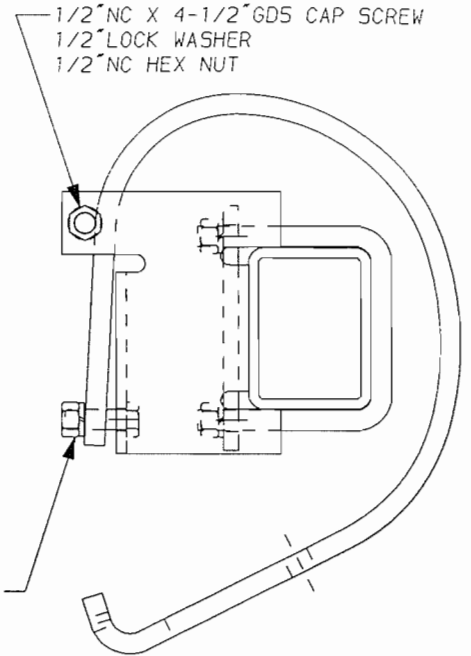

NOTE: ASSEMBLE TOP BOLT FIRST AND THEN THE LOWER BOLTS

STEP 4

M4200-140

PHOTO 25 below is showing the shank mounted to the back of the box. The shank can be mounted to the front side of the box by reversing the MOUNTING CLAMP 46.

SHANK EXTENSIONS as shown in PHOTO 26 below are U-Bolted to the frame. (See shank placement pages for locations)

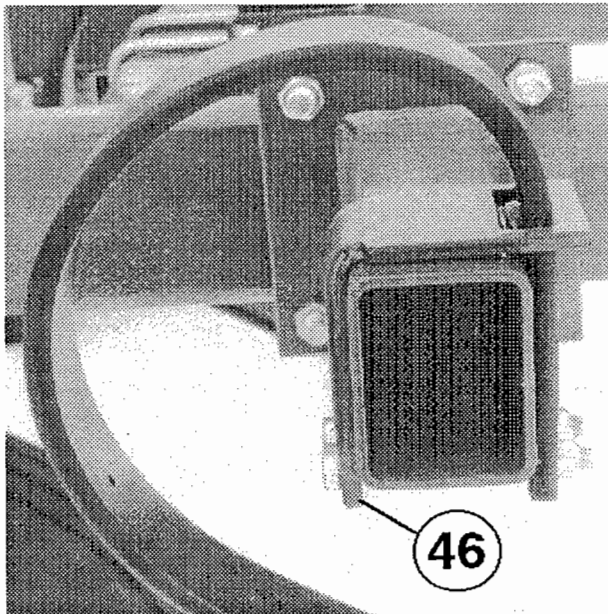

PHOTO 25

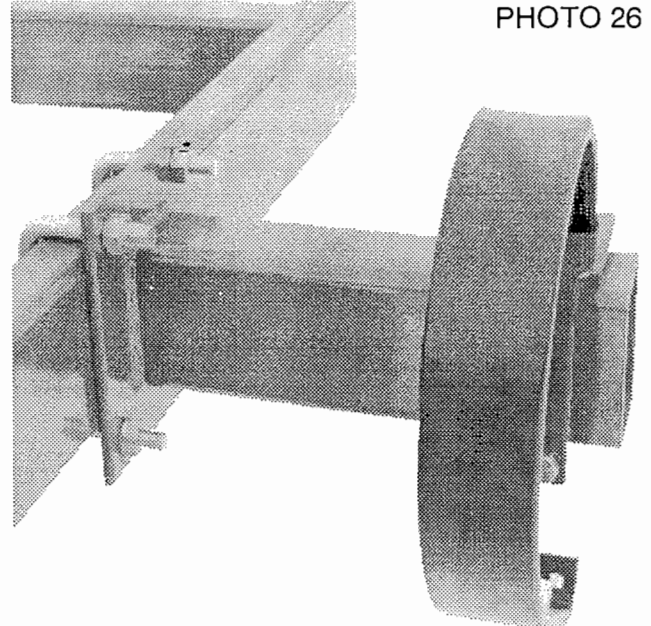
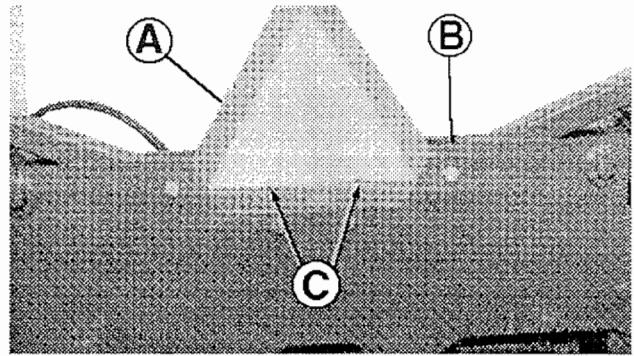

PHOTO 26

Mount tongue jack to front tongue member — mount rear jack stands to rear center frame. (See shank placement pages for location)

Install Slow Moving Vehicle (SMV) Sign. Attach SMV sign to back side of rear center lift plate (B) using two 1/4" x 1/2" bolts (C) and nuts.



HYDRAULICS

See hydraulic schematic pages for placement of hoses, fittings and clamps.

⚠ Caution: It is very important that the restrictors for the wing lift cylinders are located properly. Failure to do so may cause the wings to fall rapidly, possibly causing injury or death.

Study the following photos before starting to plumb the unit, they will aid in understanding the hydraulic schematic pages.

Pin the base end 47 of the 4" x 40" cylinders to the center section wing lift.

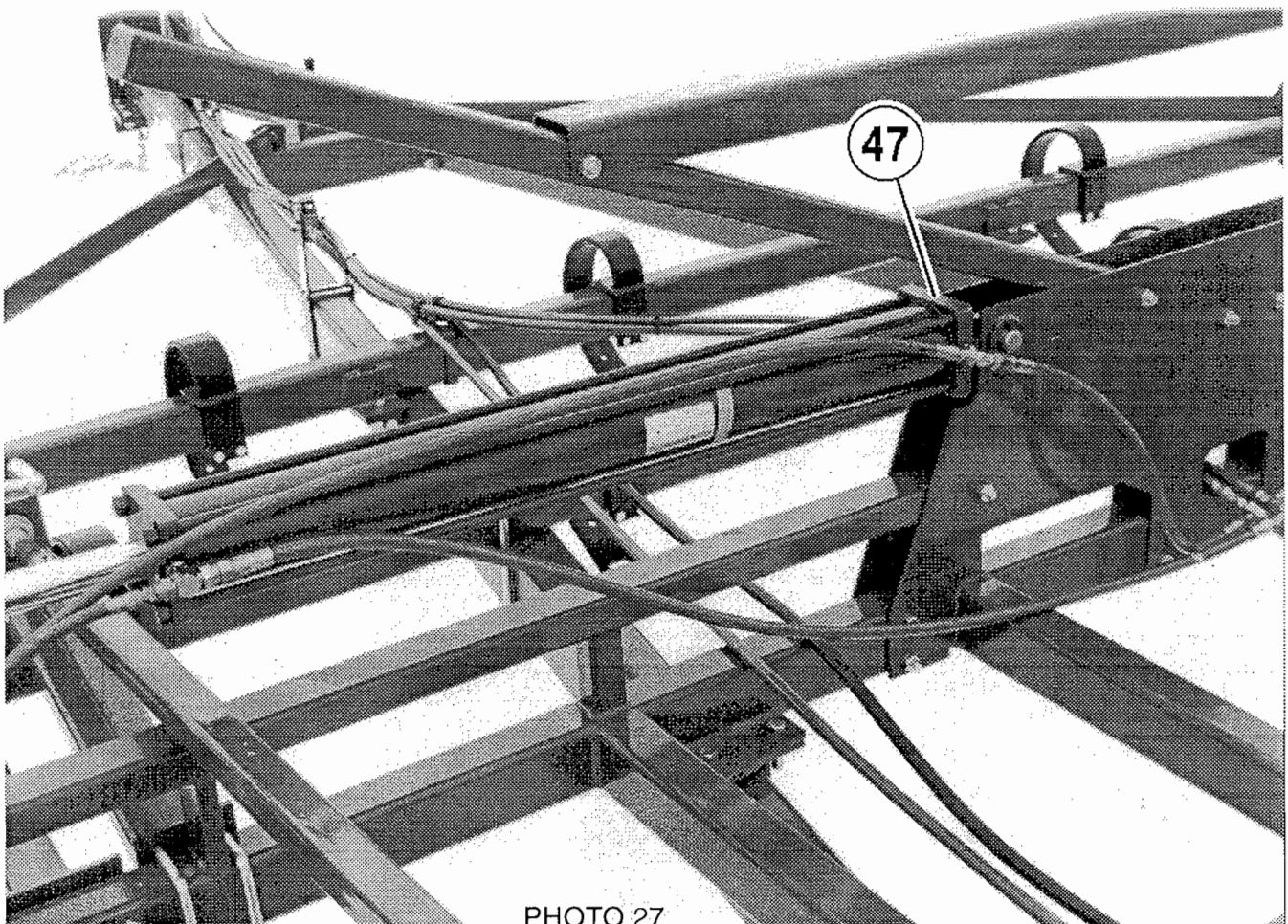

PHOTO 27

Photo of 4" x 40" cylinder on rear of center section. Note CAP 48 on end of restrictor fitting.

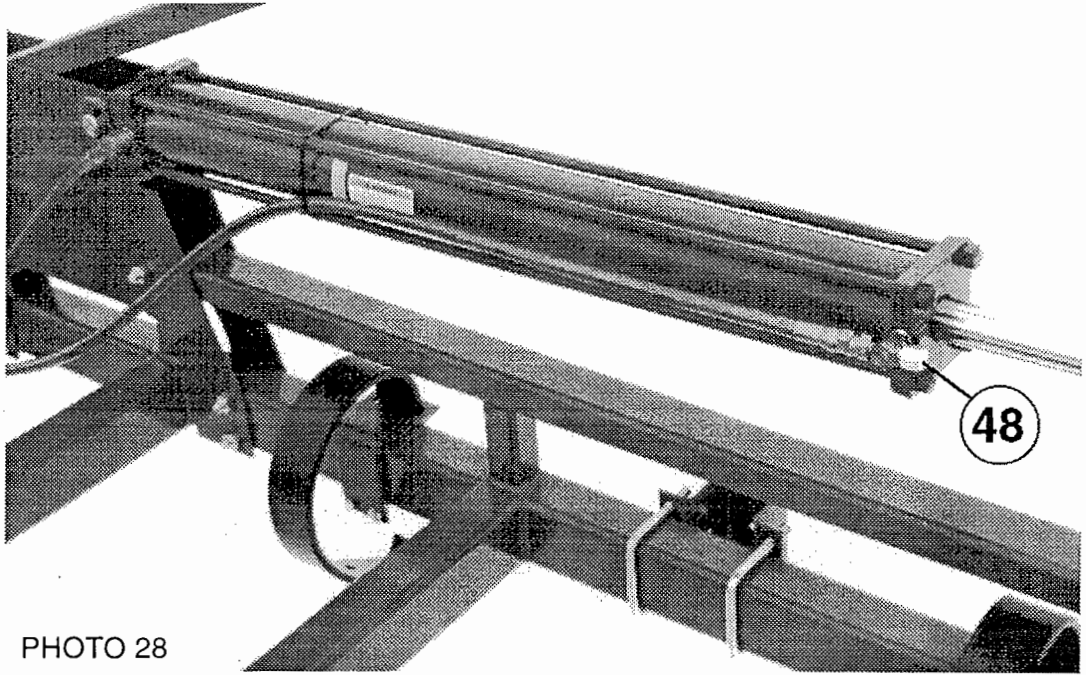

PHOTO 28

Photo of 4" x 40" cylinder on front center section.

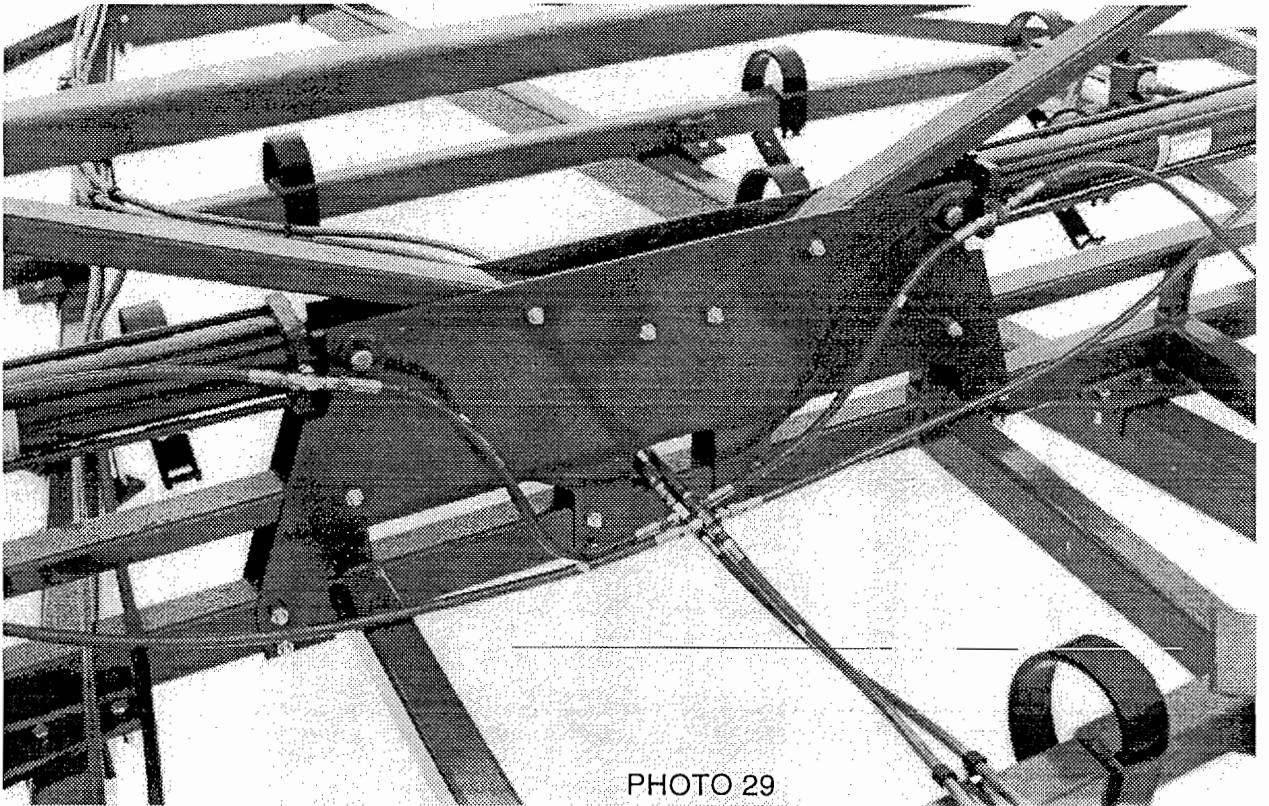

PHOTO 29

Photo of 5" x 16" cylinder on FRONT wing hinge. NOTE: Each port has a RESTRICTOR one to the base end 49 and one to the rod end 50 .

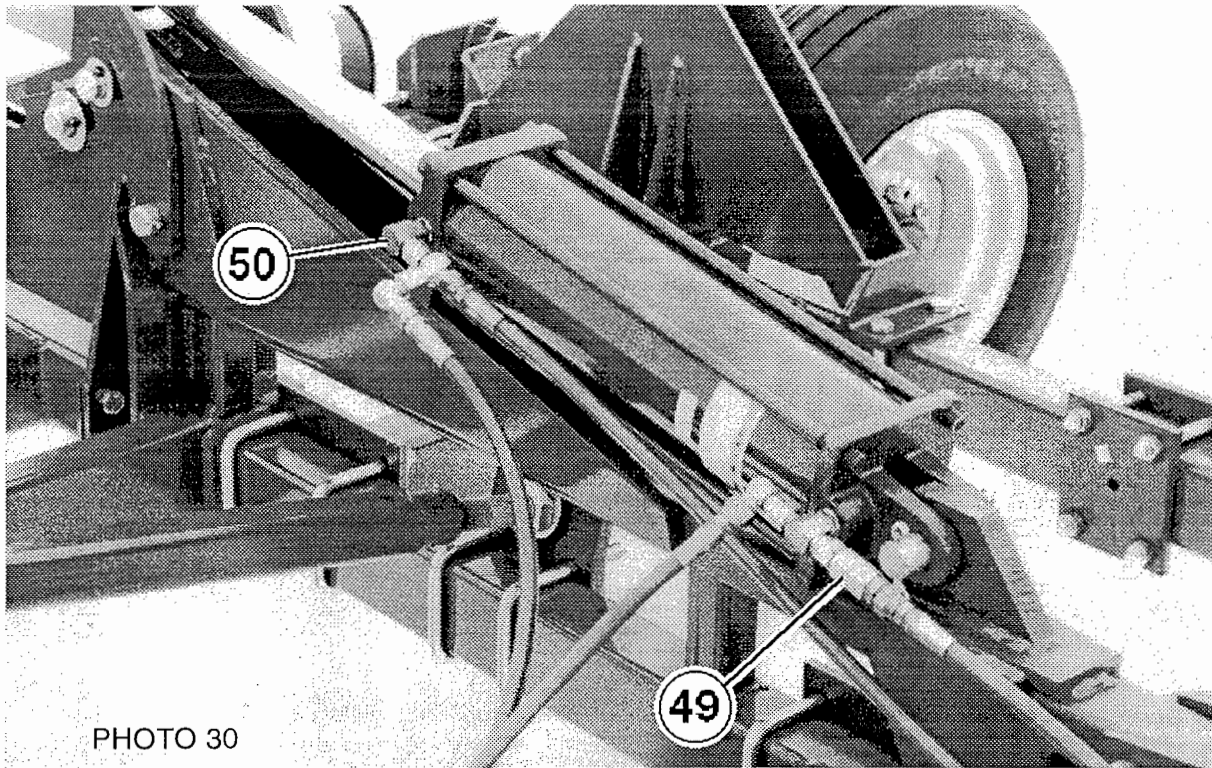

PHOTO 30

Photo showing rear 5" x 16" cylinder. Note hose tie down at 51 and 52. Do not tie down hose between 51 and 52 because the hose needs to flex at this location when the wing is folded. LEAVE SOME SLACK IN THIS HOSE.

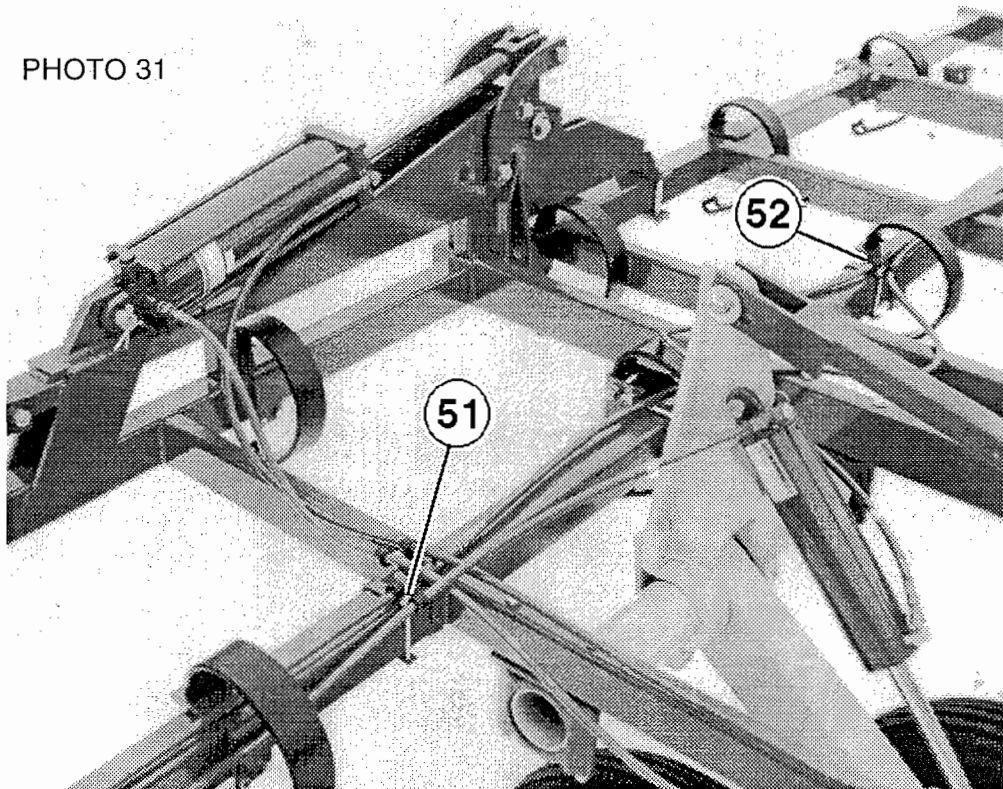
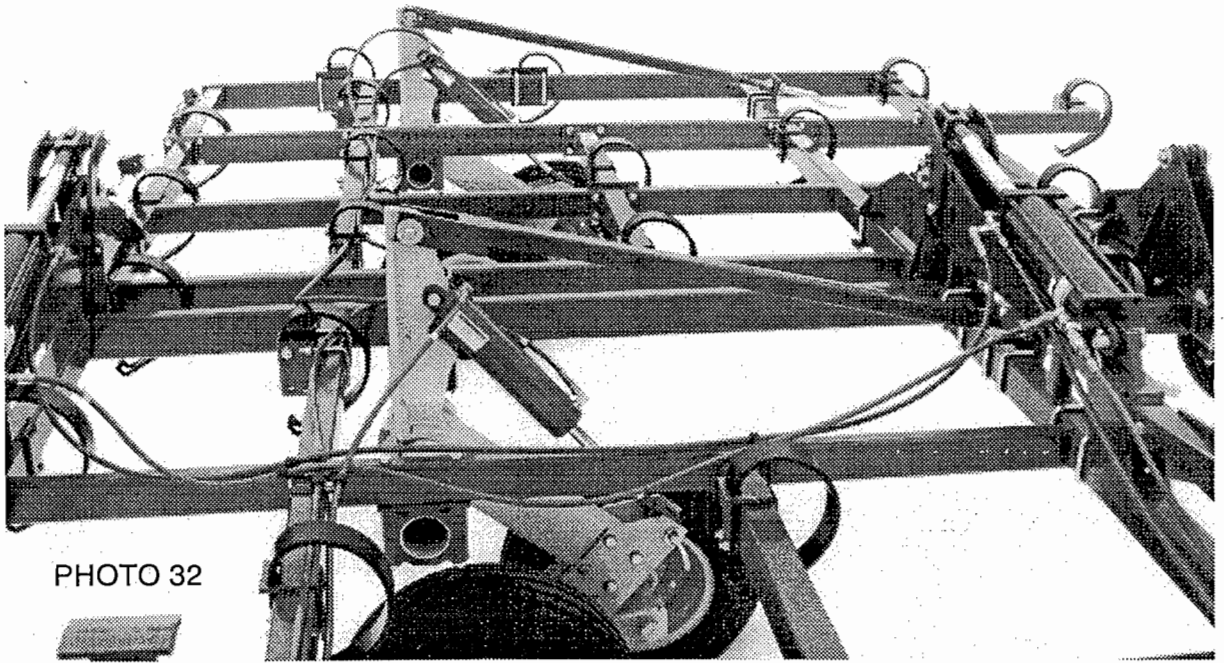

PHOTO 31

Photo showing running of hoses to Depth Control Cylinders and hoses from front 5" x 16" Wing Lift Cylinder to rear 5" x 16" Wing Lift Cylinder.



Depth Control Cylinder Center Section.

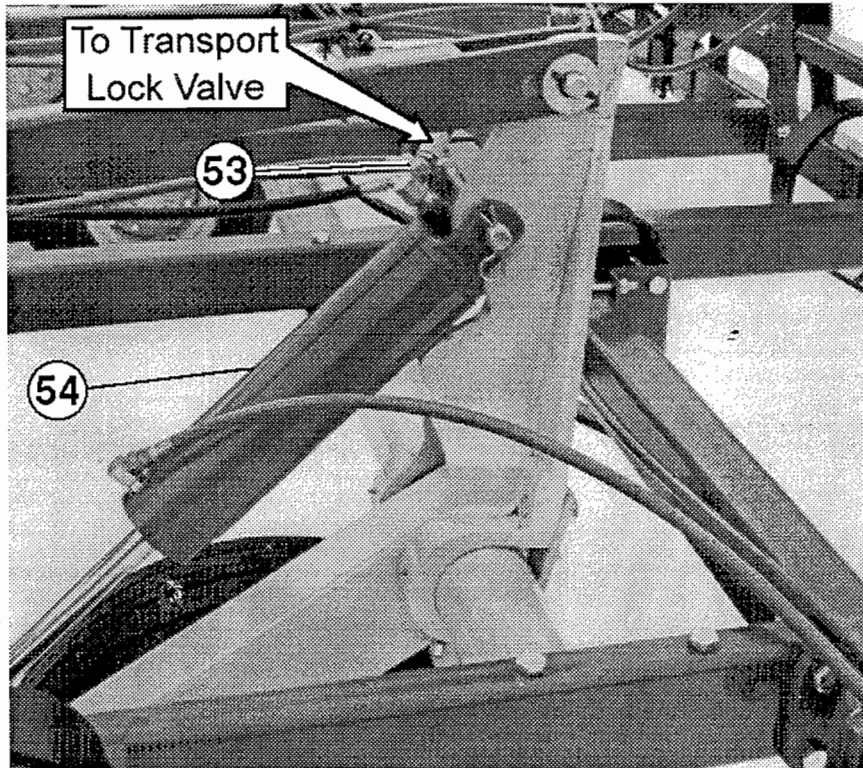
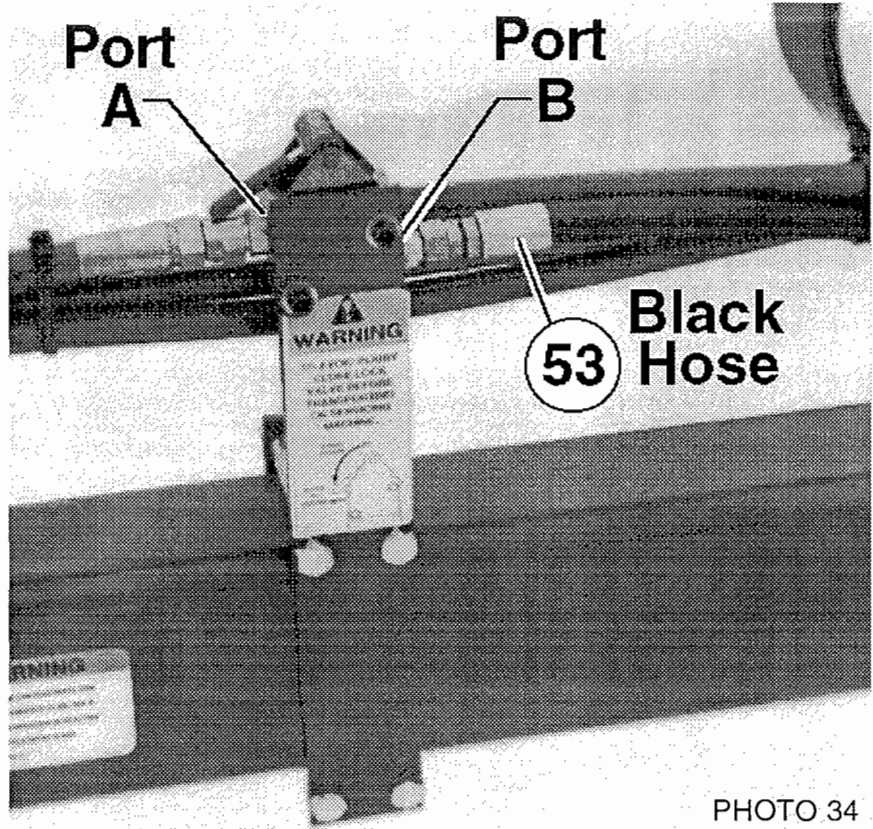

PHOTO 33 Rev.6/96

⚠ Caution: The black hydraulic hose 53 must run from the back of the valve Port B to a tee then two black hoses run to the base end ports of the center section depth control cylinders 54 . See photo number 33.

Mount transport lock valve on left tongue tube as shown.



When attaching FOUR or MORE hoses with one CLAMP 55 a SPACER NUT 56 is needed between each set of HOSE CLAMPS 57 .

PHOTO 34

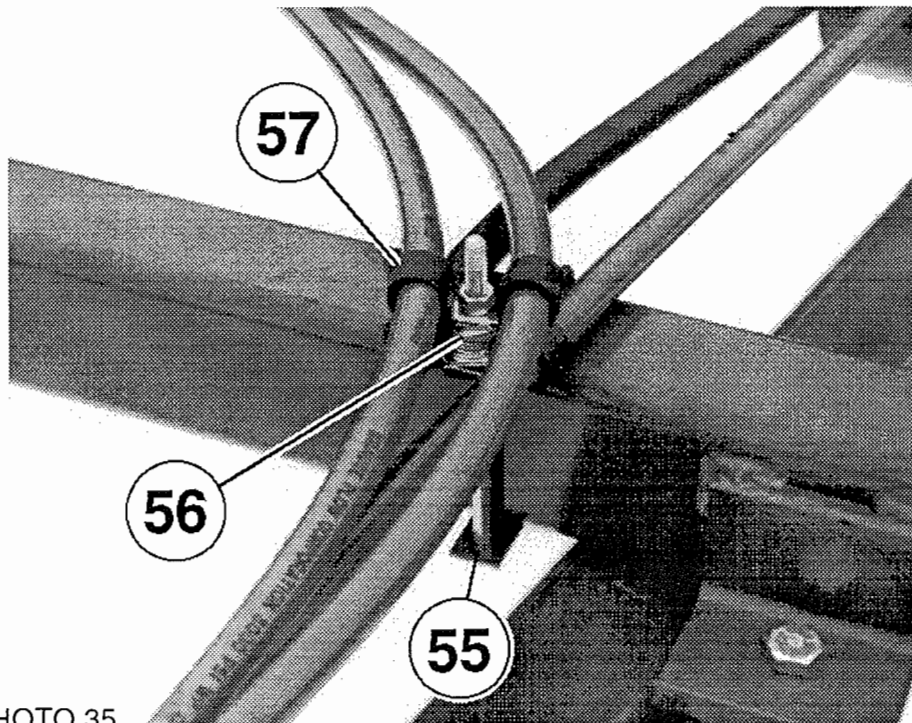

PHOTO 35

Yellow hose to **RETRACT** port. Red hose to **EXTEND** port.

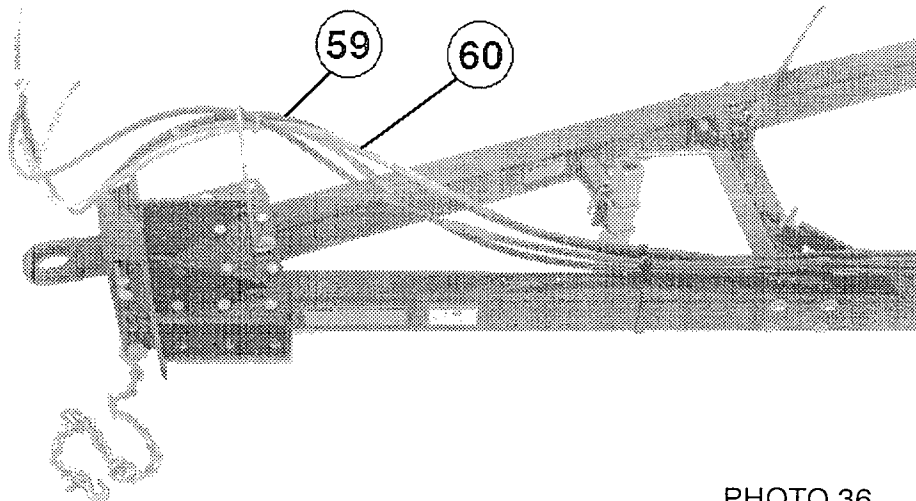

PHOTO 36



Caution: Escaping fluid under pressure can penetrate the skin causing serious injury to you or others. Relieve pressure before disconnecting hydraulic or other lines. Tighten all connections before applying pressure. Keep hands and body away from pinholes and nozzles which eject fluids under high pressure. Use a piece of cardboard or paper to search for leaks. **DO NOT USE YOUR HANDS!**

If any fluid is injected into the skin, it must be surgically removed within a few hours by a doctor familiar with this type of injury or gangrene may result.

1. Support all EIGHT wing lift cylinders on wooden blocks, so rods can be extended and retracted without interference.

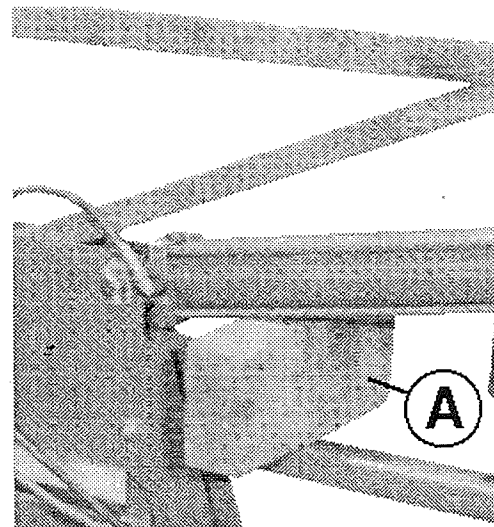
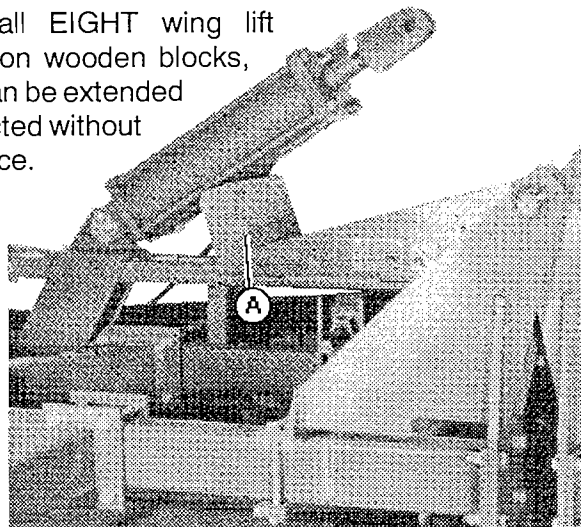

Caution: Prevent personal injury or death caused by unexpected dropping of wing. Be sure to follow correct procedure to bleed air out of hydraulic system.

2. Connect hoses to tractor. Fully extend and retract all cylinders at least two times, maintaining hydraulic pressure at full extension for at least 30 seconds. Then extend cylinders one more time, maintaining pressure at full extension for one minute. This allows all air to escape from cylinders.
3. Pin rod ends of cylinder to wing hinge locations **only** after the above steps are taken.
4. Check hydraulic system for leaks.
5. Check hose for clearance around wing hinge areas.

Caution: Observe hose as wings are being folded. Hoses must be free throughout entire range of movement. If not, damage could occur causing a wing to fall.

LIGHT KIT

Always comply with state and local laws pertaining to lighting. Install the Light Kit as shown using parts shown on page P36 of the Parts Section of this manual.

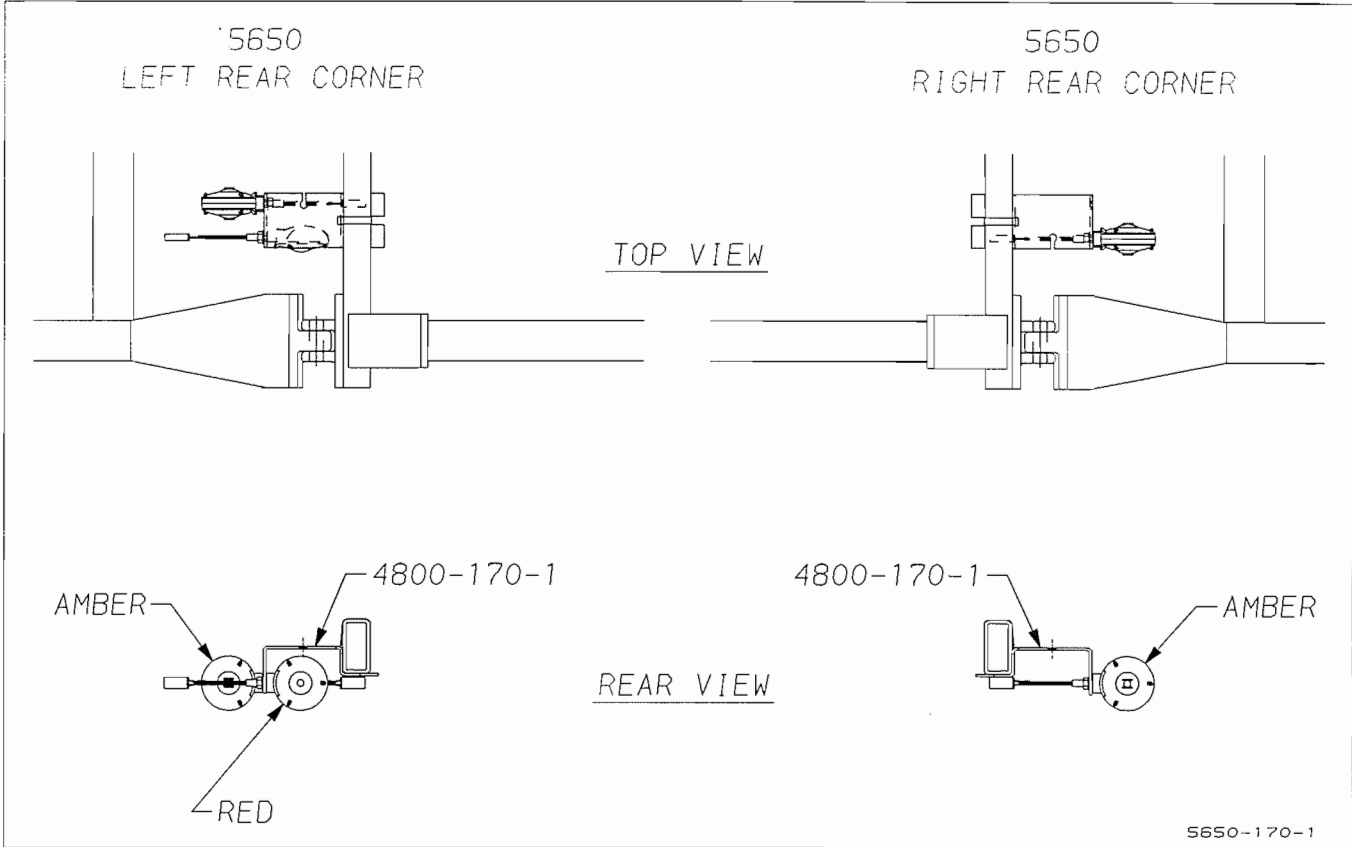

FINAL CHECK

1. Check out hydraulic system for leaks.
IMPORTANT: SEE CAUTION ON PAGE A21.
2. Lubricate all grease points.
3. Adjust depth cranks out fully. Turn counter-clockwise.
4. Fully extend depth control cylinders (see page O8), and lower rear jack stands. **CLOSE TRANSPORT LOCK VALVE.**
5. Lower tongue jack.
6. Perform final inspection. See Dealer Predelivery Check Sheet following warranty page at the front of this manual.
7. Check tires.

⚠ Caution: Explosive separation of a tire and rim parts can cause serious injury or death.

Always maintain the correct tire pressure. Do not inflate the tires above the recommended pressure. Inspect tires and wheels daily. Do not operate with low pressure, cuts, bubbles, damaged rims or missing lug bolts and nuts.

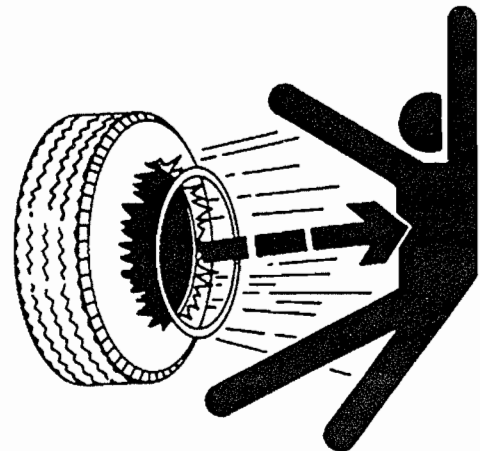

MODEL 5648 WITH 6" SPACING

RIGHT WING SECTIONS ARE SYMMETRICAL TO THE LEFT

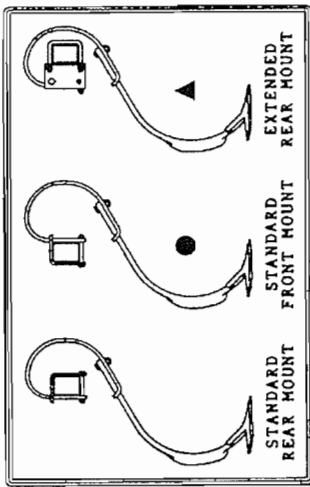
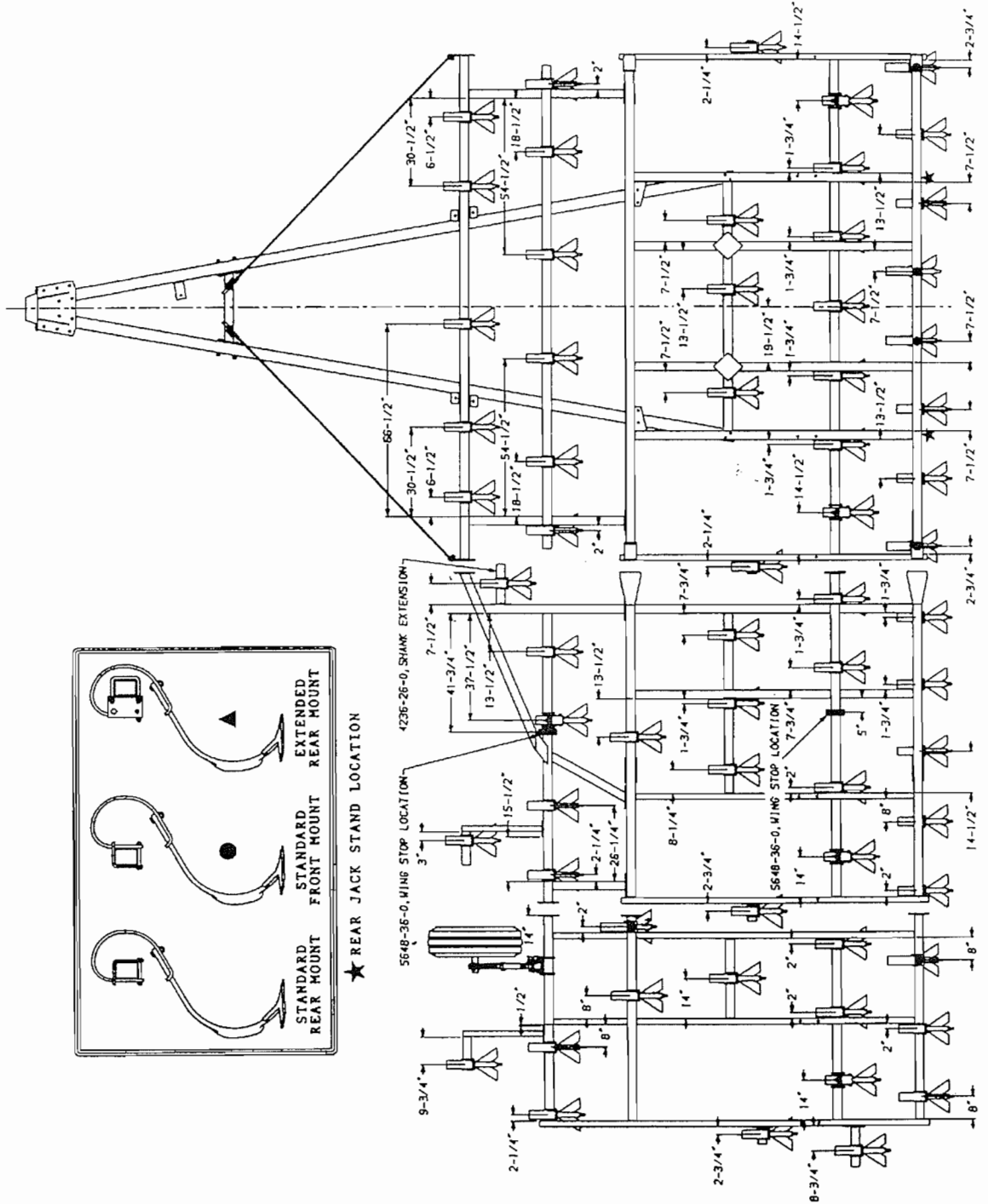

★ REAR JACK STAND LOCATION

5648-36-0, WING STOP LOCATION

4236-26-0, SHANK EXTENSION

5648-36-0, WING STOP LOCATION

MODEL 5654 WITH 9" SPACING

RIGHT WING SECTIONS ARE SYMMETRICAL TO THE LEFT

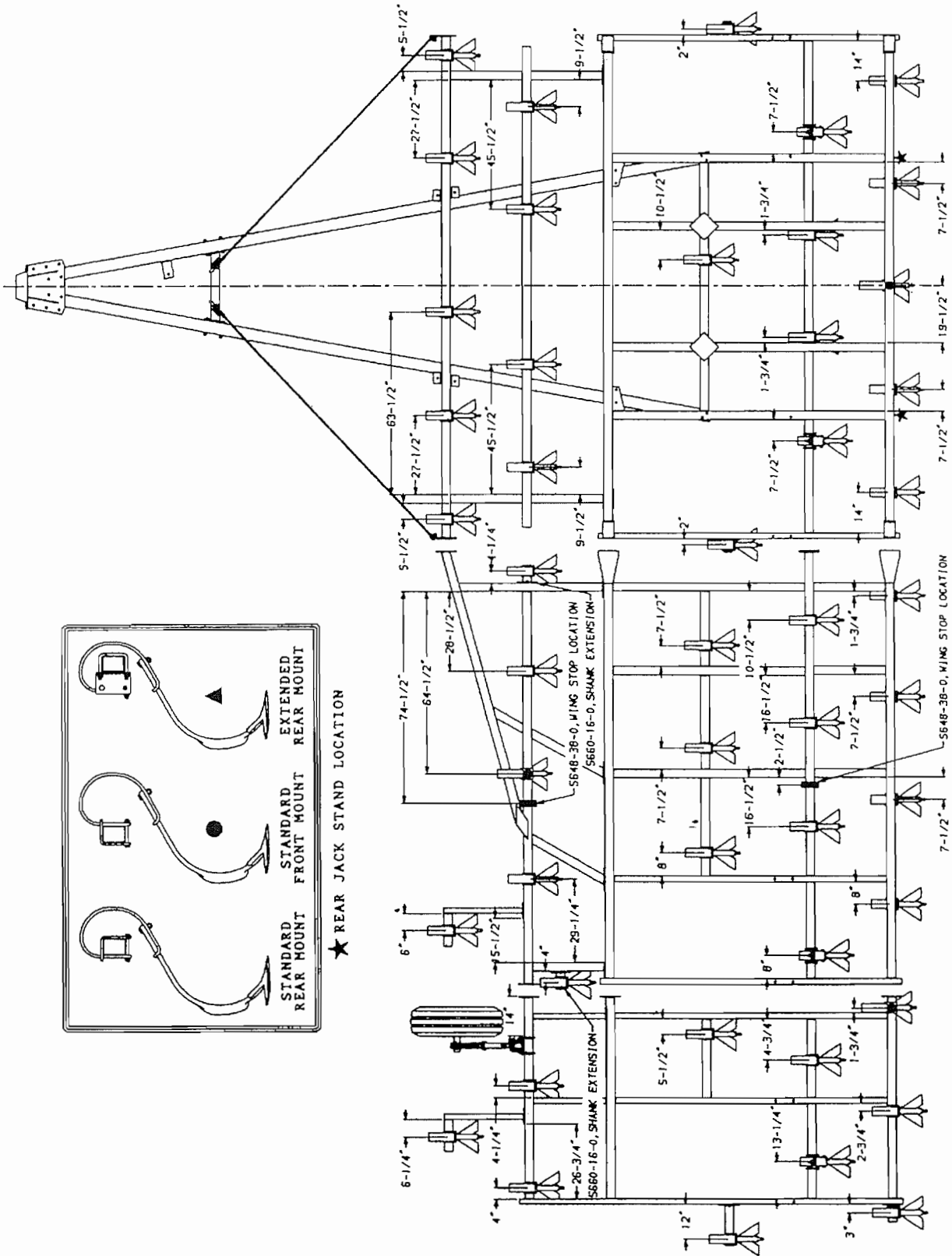



SAFETY FIRST

10

Be observant and safety minded. Recognize and correct or avoid hazardous conditions before an accident can happen. Most accidents can be prevented by practicing simple fundamental safety rules.

9

1. Read and understand the implement and tractor owner's manuals before operating.
2. Be sure safety decals and reflectors are clean and in place.
3. Do not climb or walk on gangs or frames or tires.

8

4. Never position yourself under any portion of implement unless the transport lock is engaged or entire unit is lowered to the ground.

7

5. Stop engine before leaving the operator's position to adjust, lubricate, clean or unclog the machine.

6

6. Do not stand between the implement and tractor unless the tractor brakes are locked and engine is shut off.

5

7. Do not stand on or straddle a tongue when unhitching.

4

8. Always store a winged implement with the wings down.

3

9. Never remove locking pins until hydraulic cylinders and lines are full of oil and free of air. See Operating Instructions for proper method of removing air.

2

10. Never use machinery until all safety devices are in place.

11. Release all hydraulic pressure before shutdown periods.

12. Comply with Federal, State and local laws.

13. Use a Slow-Moving-Vehicle (SMV) emblem when transporting.

14. Always use a safety chain of tensile strength equal to the gross weight of the implement and attachments when roading.

15. Towing vehicle weight must exceed weight of towed implement.

16. Check wheel bolts before and during transport.

17. Always use wing locks and road locks to hold raised positions.

18. Never permit riders on implement.

19. Do not road an implement over 15 miles per hour on the best surface conditions. Reduce speed when going up or down hills and when approaching ditches.

20. Keep small children away from farm equipment.

21. Never modify an implement without permission from the Krause Engineering Department.

3/4

22. Always use authorized Krause parts.

1/2

1/4